

KEITHLEY

MB Series

User's Guide

A GREATER MEASURE OF CONFIDENCE

WARRANTY

Hardware

Keithley Instruments, Inc. warrants that, for a period of one (1) year from the date of shipment (3 years for Models 2000, 2001, 2002, 2010 and 2700), the Keithley Hardware product will be free from defects in materials or workmanship. This warranty will be honored provided the defect has not been caused by use of the Keithley Hardware not in accordance with the instructions for the product. This warranty shall be null and void upon: (1) any modification of Keithley Hardware that is made by other than Keithley and not approved in writing by Keithley or (2) operation of the Keithley Hardware outside of the environmental specifications therefore.

Upon receiving notification of a defect in the Keithley Hardware during the warranty period, Keithley will, at its option, either repair or replace such Keithley Hardware. During the first ninety days of the warranty period, Keithley will, at its option, supply the necessary on site labor to return the product to the condition prior to the notification of a defect. Failure to notify Keithley of a defect during the warranty shall relieve Keithley of its obligations and liabilities under this warranty.

Other Hardware

The portion of the product that is not manufactured by Keithley (Other Hardware) shall not be covered by this warranty, and Keithley shall have no duty of obligation to enforce any manufacturers' warranties on behalf of the customer. On those other manufacturers' products that Keithley purchases for resale, Keithley shall have no duty of obligation to enforce any manufacturers' warranties on behalf of the customer.

Software

Keithley warrants that for a period of one (1) year from date of shipment, the Keithley produced portion of the software or firmware (Keithley Software) will conform in all material respects with the published specifications provided such Keithley Software is used on the product for which it is intended and otherwise in accordance with the instructions therefore. Keithley does not warrant that operation of the Keithley Software will be uninterrupted or error-free and/or that the Keithley Software will be adequate for the customer's intended application and/or use. This warranty shall be null and void upon any modification of the Keithley Software that is made by other than Keithley and not approved in writing by Keithley.

If Keithley receives notification of a Keithley Software nonconformity that is covered by this warranty during the warranty period, Keithley will review the conditions described in such notice. Such notice must state the published specification(s) to which the Keithley Software fails to conform and the manner in which the Keithley Software fails to conform to such published specification(s) with sufficient specificity to permit Keithley to correct such nonconformity. If Keithley determines that the Keithley Software does not conform with the published specifications, Keithley will, at its option, provide either the programming services necessary to correct such nonconformity or develop a program change to bypass such nonconformity in the Keithley Software. Failure to notify Keithley of a nonconformity during the warranty shall relieve Keithley of its obligations and liabilities under this warranty.

Other Software

OEM software that is not produced by Keithley (Other Software) shall not be covered by this warranty, and Keithley shall have no duty or obligation to enforce any OEM's warranties on behalf of the customer.

Other Items

Keithley warrants the following items for 90 days from the date of shipment: probes, cables, rechargeable batteries, diskettes, and documentation.

Items not Covered under Warranty

This warranty does not apply to fuses, non-rechargeable batteries, damage from battery leakage, or problems arising from normal wear or failure to follow instructions.

Limitation of Warranty

This warranty does not apply to defects resulting from product modification made by Purchaser without Keithley's express written consent, or by misuse of any product or part.

Disclaimer of Warranties

EXCEPT FOR THE EXPRESS WARRANTIES ABOVE KEITHLEY DISCLAIMS ALL OTHER WARRANTIES, EXPRESS OR IMPLIED, INCLUDING WITHOUT LIMITATION, ALL IMPLIED WARRANTIES OF MERCHANTABILITY AND FITNESS FOR A PARTICULAR PURPOSE. KEITHLEY DISCLAIMS ALL WARRANTIES WITH RESPECT TO THE OTHER HARDWARE AND OTHER SOFTWARE.

Limitation of Liability

KEITHLEY INSTRUMENTS SHALL IN NO EVENT, REGARDLESS OF CAUSE, ASSUME RESPONSIBILITY FOR OR BE LIABLE FOR: (1) ECONOMICAL, INCIDENTAL, CONSEQUENTIAL, INDIRECT, SPECIAL, PUNITIVE OR EXEMPLARY DAMAGES, WHETHER CLAIMED UNDER CONTRACT, TORT OR ANY OTHER LEGAL THEORY, (2) LOSS OF OR DAMAGE TO THE CUSTOMER'S DATA OR PROGRAMMING, OR (3) PENALTIES OR PENALTY CLAUSES OF ANY DESCRIPTION OR INDEMNIFICATION OF THE CUSTOMER OR OTHERS FOR COSTS, DAMAGES, OR EXPENSES RELATED TO THE GOODS OR SERVICES PROVIDED UNDER THIS WARRANTY.



Keithley Instruments, Inc.

28775 Aurora Road • Cleveland, Ohio 44139 • 440-248-0400 • Fax: 440-248-6168

1-888-KEITHLEY (534-8453) • www.keithley.com

Sales Offices: BELGIUM:

Bergensesteenweg 709 • B-1600 Sint-Pieters-Leeuw • 02-363 00 40 • Fax: 02/363 00 64

CHINA:

Yuan Chen Xin Building, Room 705 • 12 Yumin Road, Dewai, Madian • Beijing 100029 • 8610-6202-2886 • Fax: 8610-6202-2892

FINLAND:

Tietäjäsentie 2 • 02130 Espoo • Phone: 09-54 75 08 10 • Fax: 09-25 10 51 00

FRANCE:

3, allée des Garays • 91127 Palaiseau Cédex • 01-64 53 20 20 • Fax: 01-60 11 77 26

GERMANY:

Landsberger Strasse 65 • 82110 Germering • 089/84 93 07-40 • Fax: 089/84 93 07-34

GREAT BRITAIN:

Unit 2 Commerce Park, Brunel Road • Theale • Berkshire RG7 4AB • 0118 929 7500 • Fax: 0118 929 7519

INDIA:

Flat 2B, Willocrissa • 14, Rest House Crescent • Bangalore 560 001 • 91-80-509-1320/21 • Fax: 91-80-509-1322

ITALY:

Viale San Gimignano, 38 • 20146 Milano • 02-48 39 16 01 • Fax: 02-48 30 22 74

JAPAN:

New Pier Takeshiba North Tower 13F • 11-1, Kaigan 1-chome • Minato-ku, Tokyo 105-0022 • 81-3-5733-7555 • Fax: 81-3-5733-7556

KOREA:

2FL., URI Building • 2-14 Yangjae-Dong • Seocho-Gu, Seoul 137-888 • 82-2-574-7778 • Fax: 82-2-574-7838

NETHERLANDS:

Postbus 559 • 4200 AN Gorinchem • 0183-635333 • Fax: 0183-630821

SWEDEN:

c/o Regus Business Centre • Frosundaviks Allé 15, 4tr • 169 70 Solna • 08-509 04 679 • Fax: 08-655 26 10

SWITZERLAND:

Kriesbachstrasse 4 • 8600 Dübendorf • 01-821 94 44 • Fax: 01-820 30 81

TAIWAN:

1FL., 85 Po Ai Street • Hsinchu, Taiwan, R.O.C. • 886-3-572-9077 • Fax: 886-3-572-9031

MB Series User's Guide

Revision D - January 1996
Part Number: 60530

New Contact Information

Keithley Instruments, Inc.
28775 Aurora Road
Cleveland, OH 44139

Technical Support: 1-888-KEITHLEY
Monday – Friday 8:00 a.m. to 5:00 p.m (EST)
Fax: (440) 248-6168

Visit our website at <http://www.keithley.com>

The following safety precautions should be observed before using this product and any associated instrumentation. Although some instruments and accessories would normally be used with non-hazardous voltages, there are situations where hazardous conditions may be present.

This product is intended for use by qualified personnel who recognize shock hazards and are familiar with the safety precautions required to avoid possible injury. Read and follow all installation, operation, and maintenance information carefully before using the product. Refer to the manual for complete product specifications.

If the product is used in a manner not specified, the protection provided by the product may be impaired.

The types of product users are:

Responsible body is the individual or group responsible for the use and maintenance of equipment, for ensuring that the equipment is operated within its specifications and operating limits, and for ensuring that operators are adequately trained.

Operators use the product for its intended function. They must be trained in electrical safety procedures and proper use of the instrument. They must be protected from electric shock and contact with hazardous live circuits.

Maintenance personnel perform routine procedures on the product to keep it operating properly, for example, setting the line voltage or replacing consumable materials. Maintenance procedures are described in the manual. The procedures explicitly state if the operator may perform them. Otherwise, they should be performed only by service personnel.

Service personnel are trained to work on live circuits, and perform safe installations and repairs of products. Only properly trained service personnel may perform installation and service procedures.

Keithley products are designed for use with electrical signals that are rated Installation Category I and Installation Category II, as described in the International Electrotechnical Commission (IEC) Standard IEC 60664. Most measurement, control, and data I/O signals are Installation Category I and must not be directly connected to mains voltage or to voltage sources with high transient over-voltages. Installation Category II connections require protection for high transient over-voltages often associated with local AC mains connections. Assume all measurement, control, and data I/O connections are for connection to Category I sources unless otherwise marked or described in the Manual.

Exercise extreme caution when a shock hazard is present. Lethal voltage may be present on cable connector jacks or test fixtures. The American National Standards Institute (ANSI) states that a shock hazard exists when voltage levels greater than 30V RMS, 42.4V peak, or 60VDC are present. **A good safety practice is to expect that hazardous voltage is present in any unknown circuit before measuring.**

Operators of this product must be protected from electric shock at all times. The responsible body must ensure that operators are prevented access and/or insulated from every connection point. In some cases, connections must be exposed to potential human contact. Product operators in these circumstances must be trained to protect themselves from the risk of electric shock. If the circuit is capable of operating at or above 1000 volts, **no conductive part of the circuit may be exposed.**

Do not connect switching cards directly to unlimited power circuits. They are intended to be used with impedance limited sources. NEVER connect switching cards directly to AC mains. When connecting sources to switching cards, install protective devices to limit fault current and voltage to the card.

Before operating an instrument, make sure the line cord is connected to a properly grounded power receptacle. Inspect the connecting cables, test leads, and jumpers for possible wear, cracks, or breaks before each use.

When installing equipment where access to the main power cord is restricted, such as rack mounting, a separate main input power disconnect device must be provided, in close proximity to the equipment and within easy reach of the operator.

For maximum safety, do not touch the product, test cables, or any other instruments while power is applied to the circuit under test. ALWAYS remove power from the entire test system and discharge any capacitors before: connecting or disconnecting cables or jumpers, installing or removing switching cards, or making internal changes, such as installing or removing jumpers.

Do not touch any object that could provide a current path to the common side of the circuit under test or power line (earth) ground. Always make measurements with dry hands while standing on a dry, insulated surface capable of withstanding the voltage being measured.



The instrument and accessories must be used in accordance with its specifications and operating instructions or the safety of the equipment may be impaired.

Do not exceed the maximum signal levels of the instruments and accessories, as defined in the specifications and operating information, and as shown on the instrument or test fixture panels, or switching card.

When fuses are used in a product, replace with same type and rating for continued protection against fire hazard.

Chassis connections must only be used as shield connections for measuring circuits, NOT as safety earth ground connections.

If you are using a test fixture, keep the lid closed while power is applied to the device under test. Safe operation requires the use of a lid interlock.

If  or  is present, connect it to safety earth ground using the wire recommended in the user documentation.

The  symbol on an instrument indicates that the user should refer to the operating instructions located in the manual.

The  symbol on an instrument shows that it can source or measure 1000 volts or more, including the combined effect of normal and common mode voltages. Use standard safety precautions to avoid personal contact with these voltages.

The **WARNING** heading in a manual explains dangers that might result in personal injury or death. Always read the associated information very carefully before performing the indicated procedure.

The **CAUTION** heading in a manual explains hazards that could damage the instrument. Such damage may invalidate the warranty.

Instrumentation and accessories shall not be connected to humans.

Before performing any maintenance, disconnect the line cord and all test cables.

To maintain protection from electric shock and fire, replacement components in mains circuits, including the power transformer, test leads, and input jacks, must be purchased from Keithley Instruments. Standard fuses, with applicable national safety approvals, may be used if the rating and type are the same. Other components that are not safety related may be purchased from other suppliers as long as they are equivalent to the original component. (Note that selected parts should be purchased only through Keithley Instruments to maintain accuracy and functionality of the product.) If you are unsure about the applicability of a replacement component, call a Keithley Instruments office for information.

To clean an instrument, use a damp cloth or mild, water based cleaner. Clean the exterior of the instrument only. Do not apply cleaner directly to the instrument or allow liquids to enter or spill on the instrument. Products that consist of a circuit board with no case or chassis (e.g., data acquisition board for installation into a computer) should never require cleaning if handled according to instructions. If the board becomes contaminated and operation is affected, the board should be returned to the factory for proper cleaning/servicing.

The information contained in this manual is believed to be accurate and reliable. However, Keithley Instruments, Inc., assumes no responsibility for its use or for any infringements or patents or other rights of third parties that may result from its use. No license is granted by implication or otherwise under any patent rights of Keithley Instruments, Inc.

KEITHLEY INSTRUMENTS, INC., SHALL NOT BE LIABLE FOR ANY SPECIAL, INCIDENTAL, OR CONSEQUENTIAL DAMAGES RELATED TO THE USE OF THIS PRODUCT. THIS PRODUCT IS NOT DESIGNED WITH COMPONENTS OF A LEVEL OF RELIABILITY SUITABLE FOR USE IN LIFE SUPPORT OR CRITICAL APPLICATIONS.

Refer to your Keithley Instruments license agreement for specific warranty and liability information.

All brand and product names are trademarks or registered trademarks of their respective companies.

© Copyright Keithley Instruments, Inc., 1993, 1996.

All rights reserved. Reproduction or adaptation of any part of this documentation beyond that permitted by Section 117 of the 1976 United States Copyright Act without permission of the Copyright owner is unlawful.

Keithley MetraByte

440 Myles Standish Blvd. Taunton, MA 02780

Telephone: (508) 880-3000 • FAX: (508) 880-0179

Table of Contents

Preface

Manual Organization	xi
Repair and Return Policy	xi

1 Introduction

MB Series Modules	1-1
Performance	1-1
Protection	1-2
Physical Characteristics	1-2
Input Modules	1-4
Output Module	1-5
MBAF Series Active Low-Pass Filter Modules	1-6
MB Series Backplanes	1-8
Applications	1-9

2 Setting Up an MB Series System

Installing the MB Series Backplane	2-2
Selecting a Site	2-2
Mounting the Backplane	2-2
Mounting: MB01, MB02, and MB05	2-2
Mounting: MB03 and MB04	2-3
Mounting: STA-1360	2-3
Mounting: STA-MB	2-3
Connecting Power	2-4
Power: MB01, MB02, and MB05	2-5
Power: MB03, MB04, and STA-1360	2-6
Power: STA-MB	2-7
Using an Auxiliary Power Supply	2-7
Using DAS Board Power	2-8
Grounding the Backplane (MB01, MB02, and MB05)	2-10
Installing MB Series Modules in the Backplane	2-11
Connecting Signals to the Backplane	2-12
Physical Connection	2-12
Wiring Specific Modules	2-13
Current Conversion Resistor	2-17

Connecting Backplanes to Keithley MetraByte	
Analog I/O Boards	2-18
Configuring for Single-Ended Operation	2-18
Connecting MB01 and MB05 Backplanes	2-18
Connecting the MB01/MB05 to the DAS4, DAS-8, and	
DAS-800 Series	2-19
Connecting the MB01/MB05 to the DAS-16, DAS-1200,	
DAS-1400, and DAS-1600 Series	2-20
Connecting the MB01/MB05 to the DAS-1800 Series . .	2-21
Connecting the MB01/MB05 to the DASCARD-1000	
Series	2-22
Connecting the MB01/MB05 to the DAS-20	2-23
Connecting MB02 Backplanes	2-24
Connecting the MB02 to the DAS4, DAS-8, and	
DAS-800 Series	2-25
Connecting the MB02 to the DAS-16, DAS-1200,	
DAS-1400, and DAS-1600 Series	2-27
Connecting the MB02 to the DAS-1800 Series	2-29
Connecting the MB02 to the DAS-20	2-31
Connecting MB03, MB04, and STA-1360 Backplanes	2-35
Connecting STA-MB Backplanes	2-35
Wiring Module Inputs and Outputs to the DAS Board . .	2-35
Setting STA-MB Single-Ended/Differential Switches . .	2-37
Cabling to the STA-MB	2-37

3 MB Series Module Descriptions

MB30 and MB31 Millivolt and Voltage Input Modules	3-2
MB32 Current Input Module	3-7
MB34 RTD Input Module	3-11
MB36 Potentiometer Input Module	3-16
MB37 Thermocouple Input Module	3-20
MB38 Strain Gauge Input Module	3-25
MB39 Current Output Module	3-29
MB40 and MB41 Wide Bandwidth Millivolt/Volt Input	
Modules	3-34
MB45 Frequency Input Module	3-39
MB47 Linearized Thermocouple Input Module	3-43
MBAF Series Low-Pass Active Filter Modules	3-48

4	MB Series Backplane Descriptions	
	MB01, MB02, and MB05 Backplanes	4-1
	System Connectors	4-4
	MB01 and MB05 System Connectors	4-4
	MB02 System Connector	4-6
	Grounding	4-7
	Power	4-8
	Field Terminations	4-8
	Interchannel Bridge Jumpers (MB01 and MB05 Only)	4-9
	Address Selection Jumpers (MB02 Only)	4-9
	Mounting	4-10
	Dimensions	4-10
	RMT-MBBP Rack Enclosure	4-12
	Specifications	4-13
	MB03 and MB04 Backplanes	4-14
	Grounding	4-16
	Power	4-16
	Field Terminations	4-16
	Mounting	4-16
	Specifications	4-17
	STA-1360 Evaluation Socket	4-18
	Grounding	4-19
	Power	4-19
	Field Terminations	4-19
	Cold Junction Compensation	4-20
	Mounting	4-21
	STA-MB Backplane	4-21
	Power	4-23
	Mounting	4-23
	Wiring	4-23

Index

List of Figures

Figure 1-1.	MB Series Module Outline and Pinout	1-3
Figure 1-2.	Block Diagram of a General Measurement and Control Application	1-9
Figure 2-1.	Mounting the Backplane in the Rack-Mount Enclosure	2-3
Figure 2-2.	Power Terminal Block Locations: MB01, MB02, and MB05	2-5

Figure 2-3.	Wiring the Power Supply to the Backplane	2-6
Figure 2-4.	Power Terminal Block Locations: MB03, MB04, STA-1360	2-6
Figure 2-5.	Power Terminal Block Location: STA-MB	2-7
Figure 2-6.	Wiring Power to the STA-MB from a DAS-1600 Series Board	2-9
Figure 2-7.	Ground Stud Locations	2-10
Figure 2-8.	Mounting an MB Series Module.	2-11
Figure 2-9.	Connecting Signal Wires.	2-12
Figure 2-10.	Installing the Current Conversion Resistor (MB01, MB02, MB03, MB05, STA-1360, STA-MB)	2-17
Figure 2-11.	Typical MB01 or MB05 Application	2-18
Figure 2-12.	Location of Pin 1 on MB01 or MB05 Connectors.	2-19
Figure 2-13.	Connecting the DAS-4, DAS-8, or DAS-800 Series to the MB01/MB05	2-20
Figure 2-14.	Connecting the DAS-16, DAS-1200, DAS-1400, or DAS-1600 Series to the MB01/MB05	2-20
Figure 2-15.	Connecting the DAS-1800ST/HR/AO Series to the MB01/MB05 using an STA-1800U	2-21
Figure 2-16.	Connecting the DAS-1800HC Series to the MB01/MB05 using the STA-1800HC or CONN-1800HC.	2-22
Figure 2-17.	Connecting the DASCARD-1000 Series to the MB01/MB05 using an STA-U	2-23
Figure 2-18.	Connecting the DAS-20 to the MB01/MB05	2-23
Figure 2-19.	Typical MB02 Application	2-24
Figure 2-20.	Location of Pin 1 on the MB02 Connector	2-25
Figure 2-21.	Connecting the DAS-4, DAS-8, or DAS-800 Series to the MB02	2-26
Figure 2-22.	Connecting the DAS-4, DAS-8, or DAS-800 Series to the MB02 using the STA-SCM8	2-26
Figure 2-23.	Connecting the DAS-16 or DAS-1200/1400/ 1600 Series to the MB02.	2-28
Figure 2-24.	Connecting the DAS-16 or DAS-1200/1400/ 1600 Series to the MB02 using the STA-SCM16	2-28
Figure 2-25.	Connecting the DAS-1800ST/HR/AO Series to the MB02 using an STA-1800U	2-29
Figure 2-26.	Daisy-Chaining STA-1800U Accessories with MB02 Backplanes.	2-30

Figure 2-27.	Connecting the DAS-20 to the MB02	2-31
Figure 2-28.	MB02 Address Jumper Locations	2-32
Figure 2-29.	MB02 Address Jumper Example	2-34
Figure 2-30.	STA-MB/DAS-1600 Series Wiring Example	2-36
Figure 2-31.	STA-MB Single-Ended/Differential Switches	2-37
Figure 2-32.	Connecting the DAS-800 Series to the STA-MB	2-38
Figure 2-33.	Connecting the DAS-8 to the STA-MB using an EXP-16	2-38
Figure 2-34.	Connecting the DAS-800 Series to the STA-MB using an EXP-800	2-38
Figure 2-35.	Connecting the DAS-1200/1400/1600 or DASCard-1000 Series to the STA-MB using an EXP-1600	2-39
Figure 3-1.	MB30 and MB31 Functional Block Diagram	3-3
Figure 3-2.	MB32 Functional Block Diagram	3-8
Figure 3-3.	MB34 Functional Block Diagram	3-12
Figure 3-4.	MB36 Functional Block Diagram	3-17
Figure 3-5.	MB37 Functional Block Diagram	3-22
Figure 3-6.	MB38 Functional Block Diagram	3-26
Figure 3-7.	MB39 Functional Block Diagram	3-31
Figure 3-8.	MB40 and MB41 Functional Block Diagram	3-35
Figure 3-9.	MB45 Functional Block Diagram	3-40
Figure 3-10.	MB47 Functional Block Diagram	3-45
Figure 3-11.	9-Pole Low-Pass Theoretical Frequency Response Curves	3-51
Figure 3-12.	9-Pole Low-Pass Theoretical Delay Curves	3-52
Figure 3-13.	9-Pole Low-Pass Theoretical Step Response Curves	3-53
Figure 4-1.	MB01 Backplane Diagram	4-2
Figure 4-2.	MB02 Backplane Diagram	4-3
Figure 4-3.	MB05 Backplane Diagram	4-4
Figure 4-4.	MB01/MB05 System Connector Pinout (P1 and P2)	4-5
Figure 4-5.	MB02 System Connector Pinout (P1)	4-6
Figure 4-6.	Address Selection Pins Showing Default Jumpers	4-10
Figure 4-7.	MB01 and MB02 Backplane Mounting Dimensions	4-11
Figure 4-8.	MB05 Backplane Mounting Dimensions	4-11
Figure 4-9.	RMT-MBBP Rack Mount Diagram	4-12
Figure 4-10.	RMT-MBBP Rack Mount Assembly Drawing	4-13

Figure 4-11.	MB03 Wiring Diagram	4-14
Figure 4-12.	MB04 Wiring Diagram	4-15
Figure 4-13.	STA-1360 Backplane Diagram	4-18
Figure 4-14.	STA-MB Backplane Diagram	4-22
Figure 4-15.	STA-MB/DAS-1600 Series Wiring Example . . .	4-24

List of Tables

Table 1-1.	MB Series Input Modules	1-5
Table 1-2.	MBAF Series Module Pinout	1-7
Table 1-3.	MB Series Backplanes	1-8
Table 2-1.	MB Series Module Power Requirements	2-4
Table 2-2.	MB Series Input Module Wiring Diagrams: MB01, MB02, MB03, MB04, MB05, STA-1360.	2-13
Table 2-3.	MB Series Input Module Wiring Diagrams: STA-MB	2-15
Table 2-4.	MB Series Output Module Wiring Diagram: MB01, MB02, MB03, MB04, MB05, STA-1360.	2-16
Table 2-5.	MB Series Output Module Wiring Diagram: STA-MB	2-17
Table 2-6.	MB02 Address Selection Jumpers	2-33
Table 3-1.	MB30 and MB31 Specifications	3-4
Table 3-2.	MB30 and MB31 Ordering Information	3-6
Table 3-3.	MB32 Specifications	3-9
Table 3-4.	MB32 Ordering Information	3-10
Table 3-5.	MB34 Specifications	3-13
Table 3-6.	MB34 Ordering Information	3-15
Table 3-7.	MB36 Specifications	3-18
Table 3-8.	MB36 Ordering Information	3-20
Table 3-9.	MB37 Specifications	3-23
Table 3-10.	MB37 Ordering Information	3-25
Table 3-11.	MB38 Specifications	3-27
Table 3-12.	MB38 Ordering Information	3-29
Table 3-13.	MB39 Specifications	3-32
Table 3-14.	MB39 Ordering Information	3-33
Table 3-15.	MB40 and MB41 Specifications	3-36
Table 3-16.	MB40 and MB41 Ordering Information	3-38
Table 3-17.	MB45 Specifications	3-41
Table 3-18.	MB45 Ordering Information	3-43
Table 3-19.	MB47 Specifications	3-46
Table 3-20.	MB47 Ordering Information	3-48

Table 3-21.	MBAF Series Module Specifications	3-49
Table 3-22.	MBAF-LPBU Butterworth (9-Pole) Low-Pass Theoretical Response Data	3-54
Table 3-23.	MBAF-LPBU Bessel (9-Pole) Low-Pass Theoretical Response Data	3-55
Table 3-24.	MBAF Series Model Numbers	3-56
Table 4-1.	MB02 Address Selection Jumpers	4-10
Table 4-2.	MB01, MB02, and MB05 Backplane Specifications	4-13
Table 4-3.	MB03 and MB04 Mounting Parts	4-17
Table 4-4.	MB03 and MB04 Mounting Parts for Two or More Backplanes	4-17
Table 4-5.	MB03 and MB04 Specifications	4-17
Table 4-6.	STA-1360 Mounting Parts	4-21

Preface

This manual serves both designers of systems and users of Keithley MetraByte MB Series signal conditioning modules, backplanes, and accessories. It provides specifications, ordering information, and installation and application instructions.

Manual Organization

This manual is organized as follows:

- **Chapter 1 - Introduction** provides an overview of MB Series modules (including MBAF Series modules), MB Series backplanes, and applications.
- **Chapter 2 - Setting up an MB Series System** tells how to install an MB Series backplane in an equipment rack, install MB Series modules in the backplane, wire signals to the modules, and connect Keithley MetraByte analog boards to the backplane.
- **Chapter 3 - MB Series Module Descriptions** provides detailed descriptions and specifications for each of the MB Series modules.
- **Chapter 4 - MB Series Backplane Descriptions** provides detailed descriptions and specifications for each of the MB Series backplanes.

Repair and Return Policy

If you have a problem with this product or its accessories, determine your original invoice number and purchase date and prepare a brief description of the problem. For technical support, call (508) 880-3000 between 8:00 AM and 6:00 PM EST, Monday through Friday.

If an Applications Engineer determines that the product must be returned for repair, you will be given an RMA number and additional instructions. To return the product, do the following:

1. Pack the product in its original packing materials or suitable replacements. Include a piece of paper with the following information:
 - your name, address, and telephone number
 - original invoice number and purchase date
 - brief description of the problem
 - RMA number
2. Write the RMA # on the outside of the package.
3. Ship to:

Keithley MetraByte
440 Myles Standish Blvd.
Taunton, MA 02780
ATTN: RMA (your RMA number)

1

Introduction

This chapter describes general features and applications of MB Series signal conditioning modules and backplanes. It includes the following sections:

- MB Series modules
- MBAF Series active low-pass filter modules
- MB Series backplanes
- Applications

MB Series Modules

This section describes characteristics that apply to all MB Series modules.

Performance

The MB Series provides excellent signal-conditioning performance. Each unit is laser-trimmed for high calibrated accuracy. Typical calibrated accuracy consists of $\pm 0.05\%$ span $\pm 10 \mu\text{V}$ RTI $\pm 0.05 V_z$ (RTI stands for Reference to Input; V_z is the input voltage that results in a 0 V output). Refer to the specific module description in this chapter for more detailed information.

Chopper-stabilized amplification provides low drift and outstanding long term stability without the need for potentiometer adjustments. 1500 V_{rms} transformer isolation for the signal and power sections eliminates ground loops, guards against transients, prevents common mode voltage problems, and ensures channel-to-channel isolation. 160 dB CMR (Common Mode Rejection), 90 dB NMR (Normal Mode Rejection), and RFI/EMI immunity maintain signal integrity.

Protection

All field-wired terminations, including sensor inputs, excitation circuitry, and current outputs, are protected against the inadvertent application of 240 V_{rms} line voltage. The MB Series modules meet the IEEE standard for transient voltage protection (IEEE-STD 472 (SWC)).

Physical Characteristics

All MB Series modules are identical in pinout and size as shown in Figure 1-1. Therefore, you can mix and match them on a backplane to address your exact needs. The modules are hard-potted, typically weigh 2.25 ounces (64 grams), and have sturdy 40-mil gold plated pins. The module cases are made from a thermoplastic resin that has a fire retardant rating of 94 V-O and is designed for use from -55°C to +85°C. The modules are secured in the backplane by a tapered screw that also serves as a guide for insertion.

For ready identification, the isolated input modules are labeled with white lettering on a black background and the isolated output modules are labeled with white letters on a red background.

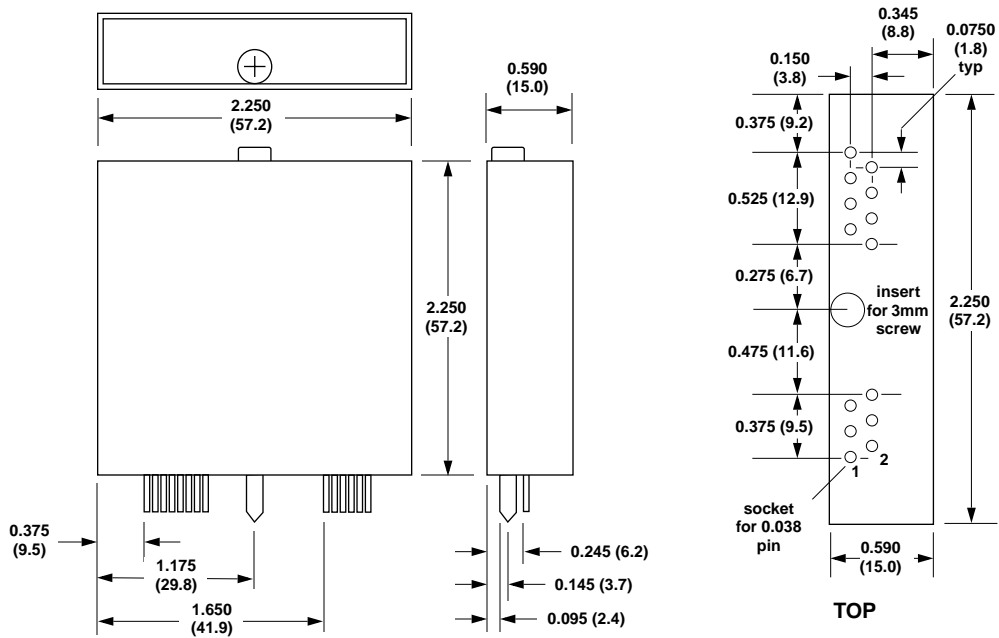

dimensions in inches and (mm)

PINOUT					
WRITE EN (0)	23	●	22	●	READ EN (0)
RESERVED	21	●	20	●	Vout
I/O COM	19	●	18	●	Vin
+5 V	17	●	16	●	POWER COM
IN LO	5	●	6	●	IN HI
- EXC	3	●	4	●	+ EXC
SENSOR -	1	●	2	●	SENSOR +

Figure 1-1. MB Series Module Outline and Pinout

Input Modules

MB Series input modules offer the following features:

- Signal source inputs:
 - Sensors: thermocouples, RTDs, potentiometers, and strain gauges
 - Millivolt and voltage sources
 - 4-20 mA or 0-20 mA process current inputs
 - frequency inputs
- Mix-and-match input capability
- High-level voltage output: -5 V to $+5\text{ V}$ or 0 to $+5\text{ V}$
- High accuracy: $\pm 0.05\%$
- Low drift: $\pm 1\ \mu\text{V}/^\circ\text{C}$
- Reliable transformer isolation: $1500\text{ V}_{\text{rms}}$ CMV (Common Mode Voltage), 160 dB CMR, meets IEEE-STD 472: Transient Protection (SWC)
- Input protection: $240\text{ V}_{\text{rms}}$ continuous
- Factory-ranged and trimmed

The MB Series input modules are galvanically isolated, single channel, plug-in signal conditioners that provide input protection, amplification and filtering, as well as a high level, series-switched analog output that can eliminate the need for external multiplexers. Key specifications include: $1500\text{ V}_{\text{rms}}$ isolation, calibrated accuracy of $\pm 0.05\%$, $\pm 0.02\%$ span nonlinearity, and low drift of $\pm 1\ \mu\text{V}/^\circ\text{C}$.

MB Series input modules are selected to meet the requirements of each application. The transfer function provided by each module is as follows:

- Input: specified sensor measurement range
- Output: 0 to $+5\text{ V}$ or -5 V to $+5\text{ V}$

Input modules are available to accept millivolt, volt, process current, thermocouple, RTD, potentiometer, frequency, and strain gauge inputs. Each module is available in a number of standard ranges to meet most applications.

Table 1-1 lists the available MB Series input modules.

Table 1-1. MB Series Input Modules

Module	Function	Output
MB30	Isolated mV Input	0 to +5 V or -5 V to +5 V
MB31	Isolated V Input	0 to +5 V or -5 V to +5 V
MB32	Isolated Current Input	0 to +5 V
MB34	Isolated 2, 3 or 4 Wire ¹ RTD Input – 100 Ω Pt, 10 Ω Cu, or 120 Ω Ni	0 to +5 V
MB36	Isolated Potentiometer Input	0 to +5 V
MB37	Isolated Thermocouple Input – Type J, K, T, E, R, S, or B	0 to +5 V
MB38	Isolated Strain Gauge Input – Full Bridge and Half Bridge	-5 V to +5 V
MB40	Isolated Wide Bandwidth mV Input	0 to +5 V or -5 V to +5 V
MB41	Isolated Wide Bandwidth V Input	0 to +5 V or -5 V to +5 V
MB45	Isolated Frequency Input	0 to +5 V
MB47	Isolated Linearized Thermocouple Input – Type J, K, T, E, R, S, or B	0 to +5 V

Notes

¹The MB34 RTD input module provides 3-wire lead resistance compensation and can be connected to 2, 3, or 4 wire RTDs.

For a more detailed description of the MB Series input modules, refer to Chapter 3.

Output Module

The MB Series output module (MB39) offers the following features:

- High-level voltage inputs: 0 to +5 V or -5 V to +5 V
- Process current output: 4-20 mA or 0-20 mA
- High accuracy: ±0.05%

- Reliable transformer isolation: 1500 V_{rms} CMV, CMR = 90 dB
- Meets IEEE-STD 472: Transient Protection (SWC)
- Output protection: 240 V_{rms} continuous
- Internal track and hold amplifier

The MB39 current output module accepts a high level analog signal at its input and provides a galvanically-isolated 4-20 mA or 0-20 mA process current signal at its output. The module features high accuracy of $\pm 0.05\%$, $\pm 0.02\%$ nonlinearity, and 1500 V_{rms} common mode voltage isolation protection. The transfer function provided by this module is as follows:

- Input: 0 to +5 V or -5 V to +5 V
- Output: 4-20 mA or 0-20 mA

For a more detailed description of the MB Series output modules, refer to Chapter 3.

MBAF Series Active Low-Pass Filter Modules

MBAF Series filters offer the following features:

- MB Series plug-compatibility
- +5 V power supply only
- Differential input
- Standard corner frequencies: 1 kHz, 2 kHz, 5 kHz, 10 kHz, 20 kHz, 50 kHz

Use MBAF Series filters for the following applications:

- Prefiltering for anti-aliasing
- Data acquisition
- Industrial process control
- Signal conditioning

The MBAF Series are differential-input 9-pole Butterworth and Bessel low-pass anti-aliasing filters that are pinout and package compatible with industry-standard MB Series signal conditioning modules and mechanical equivalents.

Table 1-2 shows the pinout for MBAF Series filters.

Table 1-2. MBAF Series Module Pinout

Pin	Function	Pin	Function
1	N/A	4	N/A
2	N/A	5	IN LO
3	N/A	6	IN HI
16	POWER COM	20	Vout
17	+5V	21	N/A
18	N/A	22	N/A
19	I/O COM	23	N/A

For a more detailed description of the MBAF Series modules, refer to Chapter 3.

MB Series Backplanes

Table 1-3 provides a brief summary the backplanes available for use with MB Series modules.

Table 1-3. MB Series Backplanes

Model	Description
MB01	Holds up to 16 modules and mounts in a 19-inch equipment rack. Provides direct channel-to-channel connection to an analog board making it suitable for high-speed, high-resolution applications.
MB02	Holds up to 16 modules and mounts in a 19-inch equipment rack. Up to four MB02s can be multiplexed together, providing a total of 64 channels. This makes it suitable for larger systems.
MB03	DIN-rail compatible backplane that holds one module.
MB04	DIN-rail compatible backplane that holds two modules.
MB05	Holds up to eight modules and mounts in a 19-inch equipment rack. Provides direct channel-to-channel connection to an analog board making it suitable for high-speed, high-resolution applications.
STA-1360	Stand-alone test/evaluation socket for one module.
STA-MB	Provides sockets for four modules.

For a more detailed description of the MB Series backplanes, refer to Chapter 4.

Applications

Typical MB Series applications include mini- and microcomputer-based measurement systems, standard data acquisition systems, programmable controllers, analog recorders, and dedicated control systems. MB Series modules are ideally suited to applications where monitoring and control of temperature, pressure, flow, and other analog signals are required. Figure 1-2 shows a block diagram of a general MB Series measurement and control application.

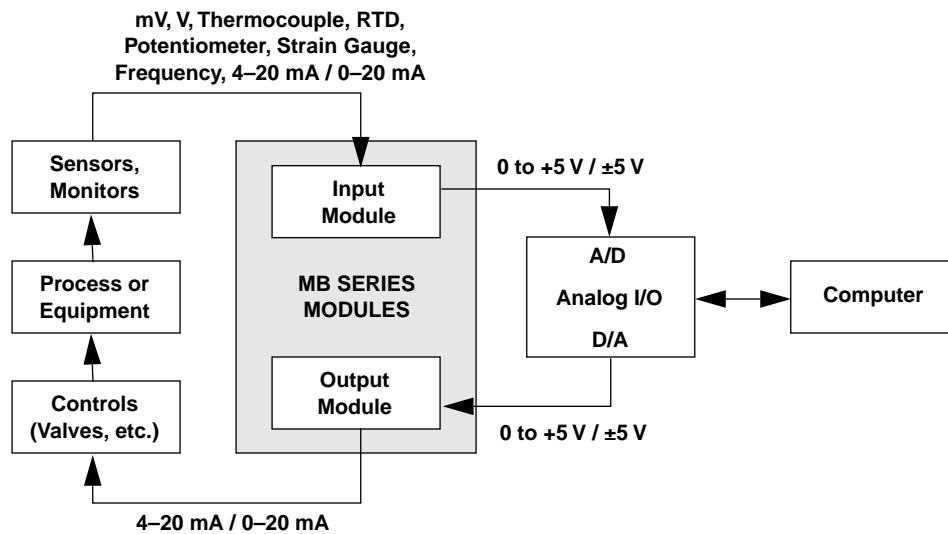

Figure 1-2. Block Diagram of a General Measurement and Control Application

2

Setting Up an MB Series System

This chapter tells how to set up an MB Series system consisting of a backplane, signal conditioning modules, and an analog I/O board. It discusses the MB01, MB02, MB03, MB04, MB05, STA-1360, and STA-MB backplanes. This chapter includes the following sections:

- Installing an MB Series backplane
- Installing MB Series modules in the backplane
- Connecting signals to the backplane
- Connecting backplanes to Keithley MetraByte analog I/O boards

Caution: To prevent damage to MB Series components due to static discharge, wear a grounded wrist strap or similar device whenever handling backplanes or modules.

Installing the MB Series Backplane

This section tells how to install each of the MB Series backplanes.

Selecting a Site

You can install the MB Series backplane and signal conditioning modules in any location suitable for general-purpose electronic equipment. The temperature in this location must be between -25°C and $+85^{\circ}\text{C}$ (-13°F and $+185^{\circ}\text{F}$) for rated performance. If the environment is harsh or unfavorable, install the backplane in a protective enclosure.

Mounting the Backplane

The different backplane models have different mounting requirements. Refer to the section below that describes mounting for your model.

Mounting: MB01, MB02, and MB05

The MB01, MB02, and MB05 backplanes mount in an RMT-MBBP rack-mount enclosure, which in turn mounts in a 19-inch equipment rack. The rack-mount enclosure has seven 3-mm threaded inserts for mounting the backplane, six threaded inserts for mounting an adaptor board on the back, and four holes for mounting a PWR-51A or PWR-55A power supply on the back. The rack-mount enclosure kit includes screws.

Note: The PWR-55A power supply has replaced the PWR-53A power supply, which is now obsolete.

To install the MB01, MB02, or MB05 backplane, perform the following steps:

1. Screw the backplane into the rack-mount enclosure as shown in Figure 2-1.
2. Attach the rack-mount enclosure to the equipment rack.

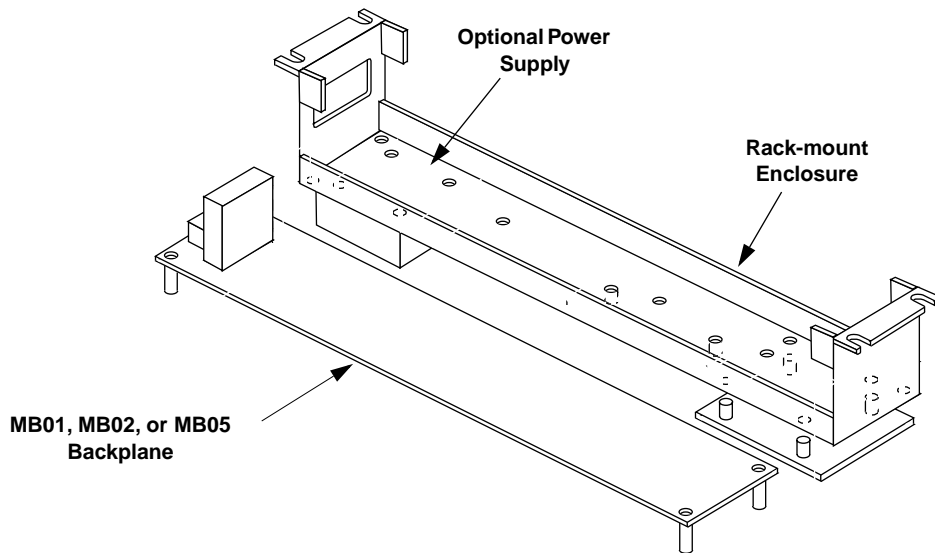

Figure 2-1. Mounting the Backplane in the Rack-Mount Enclosure

Mounting: MB03 and MB04

You can set up the MB03 and MB04 for DIN-rail mounting using special mounting hardware. Refer to Chapter 4 for ordering information.

Mounting: STA-1360

The STA-1360 ships with standoffs for bench top use. You can also set up the STA-1360 backplane for DIN-rail mounting using special mounting hardware. Refer to Chapter 4 for ordering information.

Mounting: STA-MB

The STA-MB is factory-mounted in a free-standing plastic enclosure.

Connecting Power

MB Series backplanes require external +5 V power. Before selecting a power supply, determine the total backplane current requirement. To do this, add the current requirements for the MB Series modules you plan to install in the backplane. Table 2-1 shows the current requirements for MB Series modules.

Table 2-1. MB Series Module Power Requirements

Model	Current	Model	Current
MB30	30 mA	MB38	200 mA
MB31	30 mA	MB39	170 mA ¹
MB32	30 mA	MB40	30 mA
MB34	30 mA	MB41	30 mA
MB36	30 mA	MB45	110 mA
MB37	30 mA	MB47	30 mA

Notes

¹ Maximum output load resistance is 750 Ω

Keithley offers two +5 V external supplies that mount directly to the back of the RMT-MBBP rack-mount enclosure: the PWR-51A, which delivers up to 1 A, and the PWR-55A, which delivers up to 5 A.

Refer to the section below that describes power connection for your backplane model.

Power: MB01, MB02, and MB05

To connect power to the MB01, MB02, or MB05 backplane, perform the following steps:

1. Mount the power supply in its permanent location.

If you are using the PWR-51A or PWR-55A, attach the power supply directly to the back of the rack-mount enclosure as shown in Figure 2-1.

2. Find the power terminal block on the backplane as shown in Figure 2-2.

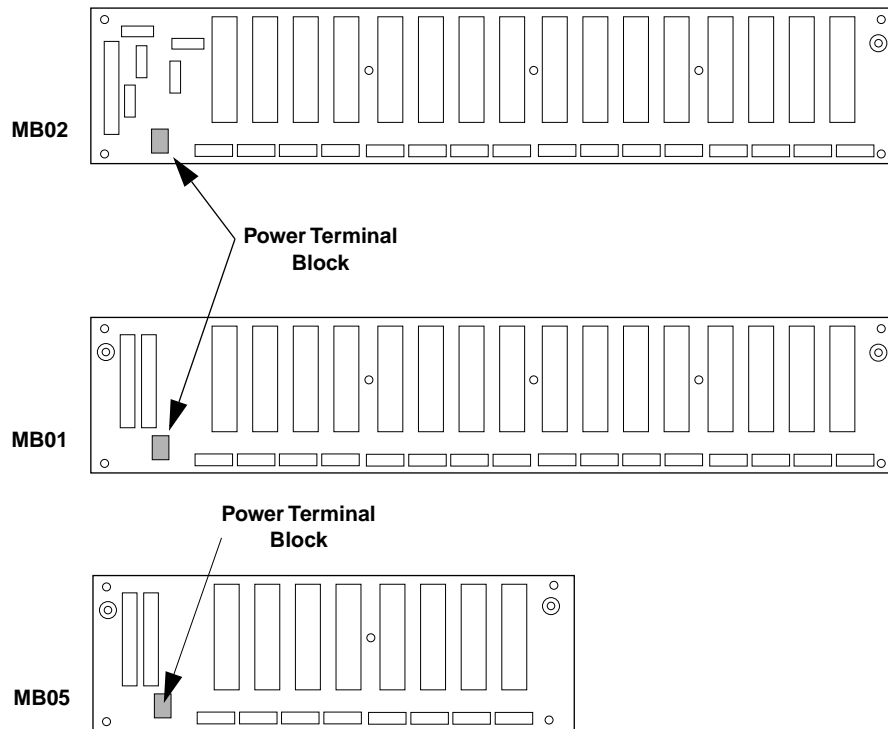

Figure 2-2. Power Terminal Block Locations: MB01, MB02, and MB05

3. Using #12 to #16 AWG wire, connect the power supply to the backplane as shown in Figure 2-3. The terminals are labeled on the board as +5 V and PWR COM.

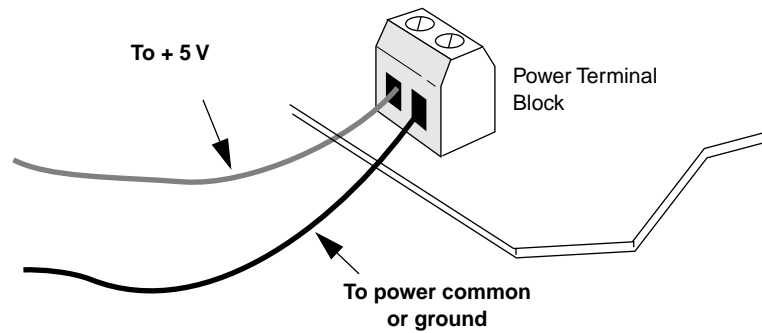

Figure 2-3. Wiring the Power Supply to the Backplane

Power: MB03, MB04, and STA-1360

Caution: The MB03, MB04, and STA-1360 do not have protection against reversed polarity. Reversing the power supply wiring to these backplanes can destroy any installed modules.

To connect power to the MB03, MB04, or STA-1360 backplane, perform the following steps:

1. Mount the power supply in its permanent location.
2. Find the power terminal block on the backplane as shown in Figure 2-4.

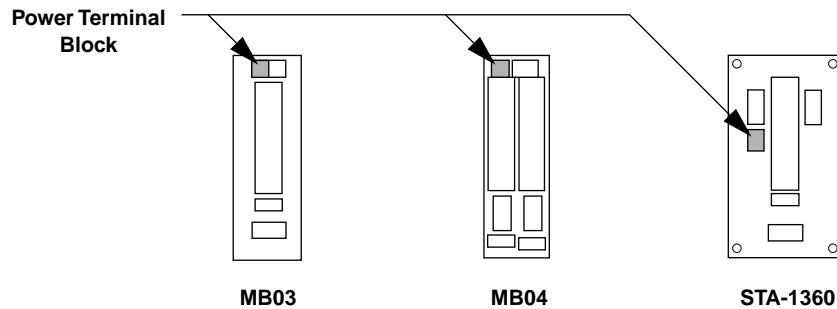

Figure 2-4. Power Terminal Block Locations: MB03, MB04, STA-1360

- Using #18 to #22 AWG wire, connect the power supply to the backplane as shown in Figure 2-3. The terminals are labeled on the board as +5 V and PWR COM.

Power: STA-MB

You can use power either from the DAS board connection or an auxiliary power supply. Refer to the section below for the method you choose.

Caution: The STA-MB does not have protection against reversed polarity. Reversing the power supply wiring to this backplane can destroy any installed modules.

Using an Auxiliary Power Supply

To connect an auxiliary power supply to the STA-MB backplane, perform the following steps:

- Mount the power supply in its permanent location.
- Find the power terminal block on the backplane as shown in Figure 2-5.

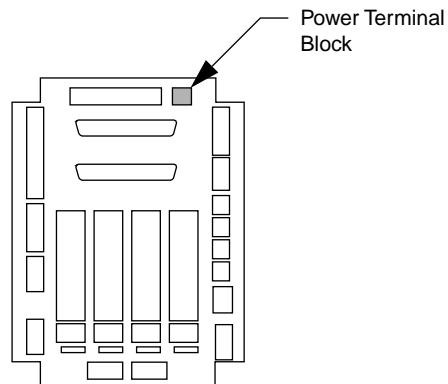

Figure 2-5. Power Terminal Block Location: STA-MB

3. Using #18 to #22 AWG wire, connect the power supply to the STA-MB power terminal block as shown in Figure 2-3. The power terminal block screw terminals are labeled on the backplane as +5 V and GND.

Using DAS Board Power

When you cable a DAS board to an STA-MB backplane, the DAS board delivers +5 V to a pair of screw terminals on the STA-MB. To use this power on the STA-MB, perform the following steps:

1. Refer to the DAS board's I/O connector pinout to determine which pins provide +5 V and POWER GROUND. For example, on the DAS-1600 I/O connector, pin 1 provides +5 V and pin 7 provides POWER GROUND.
2. On the STA-MB, find the screw terminals with the same numbers. These provide +5 V and POWER GROUND from the DAS board.
3. Find the power terminal block on the STA-MB backplane as shown in Figure 2-5.
4. Using #18 to #22 AWG wire, connect the screw terminals you located in step 2 to the STA-MB power terminal block. Figure 2-3 shows how. The power terminal block screw terminals are labeled on the backplane as +5 V and GND.

Figure 2-6 shows an STA-MB backplane wired to use power from a DAS-1600 Series board.

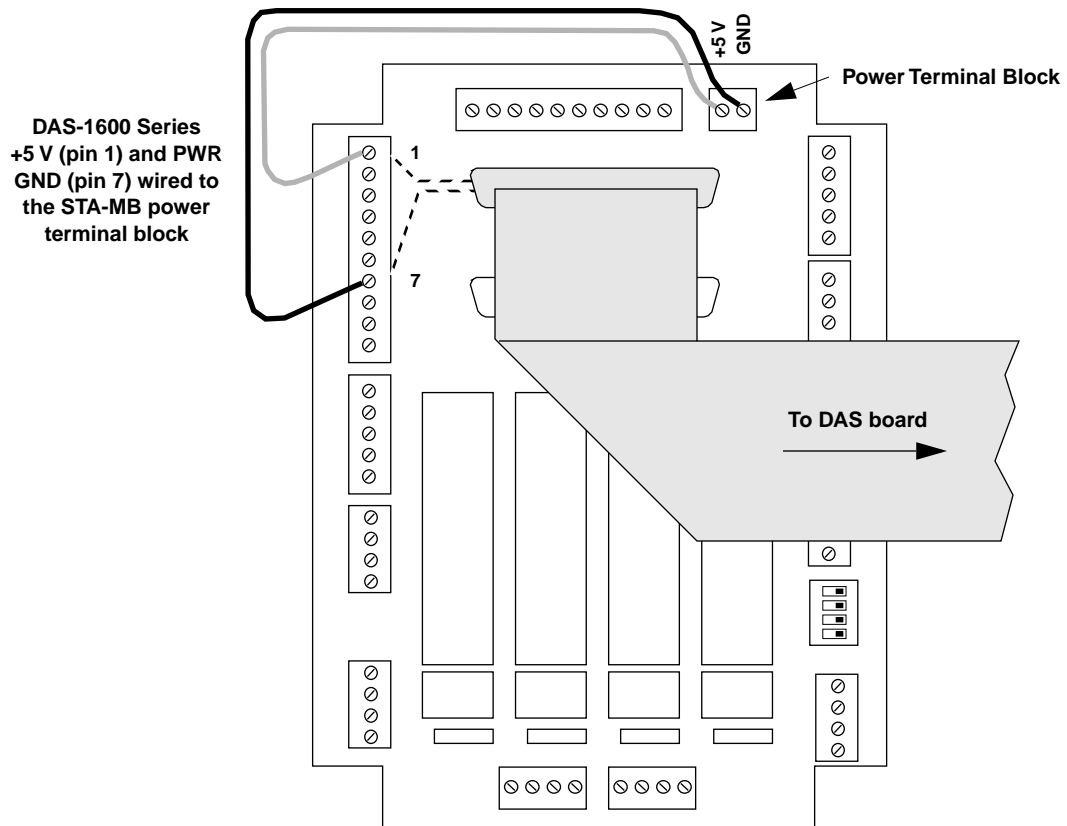

Figure 2-6. Wiring Power to the STA-MB from a DAS-1600 Series Board

Grounding the Backplane (MB01, MB02, and MB05)

MB Series modules can protect the connected system from large, fast transient strikes to signal lines. However, you must ground the backplane to ensure full protection. MB01, MB02, and MB05 backplanes provide ground studs for this purpose (shown in Figure 2-7). If the possibility of transient strikes exists, ground the backplane by connecting a ground stud to system ground using the shortest practical length of large diameter wire.

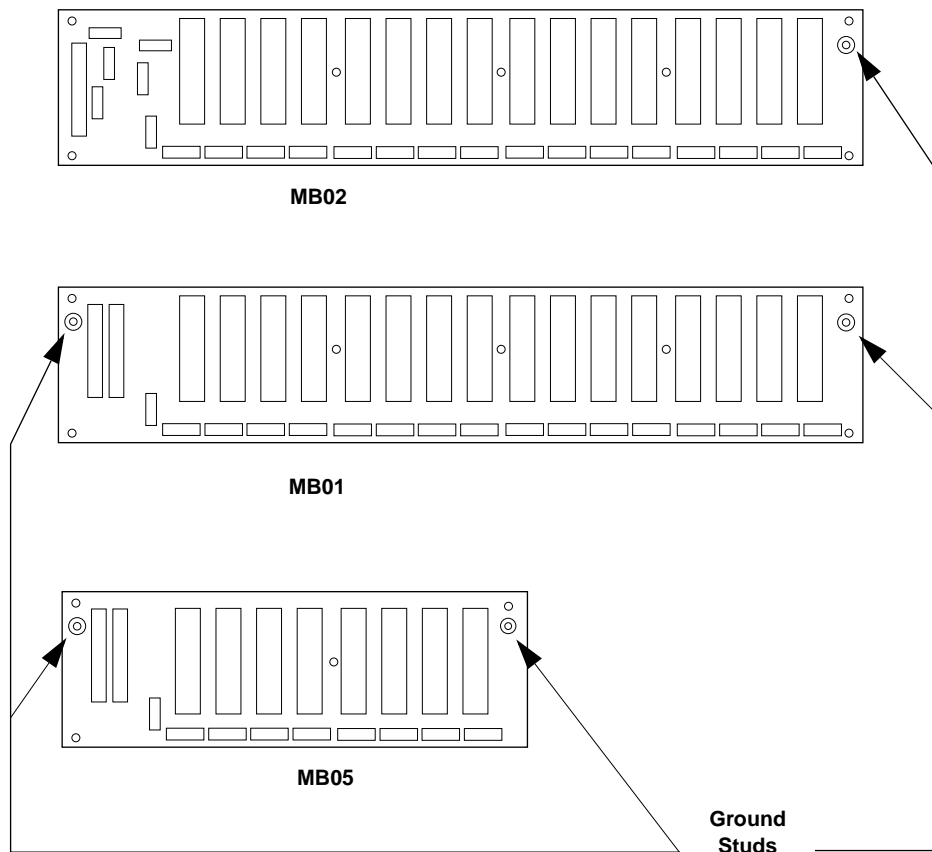

Figure 2-7. Ground Stud Locations

Installing MB Series Modules in the Backplane

To install a module in a backplane socket, perform the following steps:

1. Align the module's retaining screw (provided with the module) and connector pins with the holes in the backplane as shown in Figure 2-8.

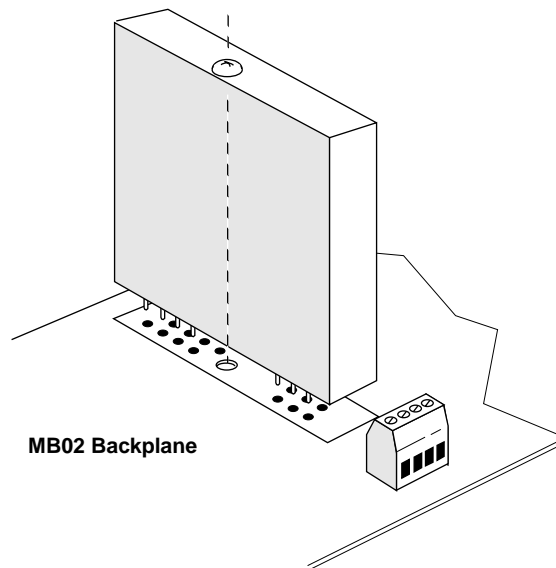

Figure 2-8. Mounting an MB Series Module

2. Gently press the module down so that the pins are fully inserted.
3. Tighten the retaining screw (do not overtighten).

Connecting Signals to the Backplane

This section provides general instructions for physically attaching signals to MB Series modules, as well as wiring diagrams for specific module models.

Physical Connection

Connect signals to an MB Series module by attaching the signal wires to the module's signal terminal block as shown in Figure 2-9. Use #14 - #22 AWG wire.

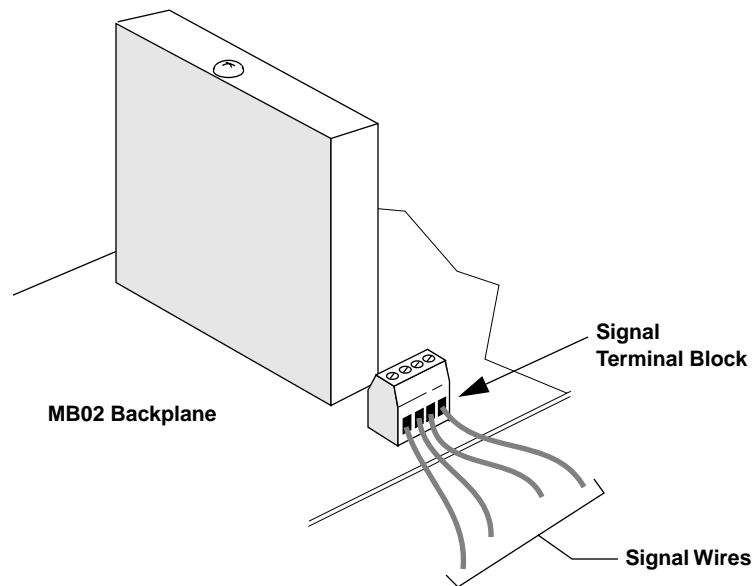

Figure 2-9. Connecting Signal Wires

Wiring Specific Modules

Table 2-2 provides wiring diagrams when attaching input modules to the MB01, MB02, MB03, MB04, MB05, and STA-1360 backplanes; Table 2-3 provides wiring diagrams when attaching input modules to the STA-MB backplane.

Table 2-4 provides wiring diagrams when attaching output modules to the MB01, MB02, MB03, MB04, MB05, and STA-1360 backplanes; Table 2-5 provides wiring diagrams when attaching output modules to the STA-MB backplane.

Caution: Make sure you use the wiring diagrams for your backplane.

**Table 2-2. MB Series Input Module Wiring Diagrams:
MB01, MB02, MB03, MB04, MB05, STA-1360**

Modules	Signal Wiring Diagram	Modules	Signal Wiring Diagram
MB30 MB31 MB40 MB41		MB37 MB47	
MB32 ¹		MB38 full-bridge	

**Table 2-2. MB Series Input Module Wiring Diagrams:
MB01, MB02, MB03, MB04, MB05, STA-1360 (cont.)**

Modules	Signal Wiring Diagram	Modules	Signal Wiring Diagram
MB34	<p>RTD</p>	MB38 half-bridge	<p>Strain Gauge</p>
MB36	<p>Potentiometer</p> <p>Slidewire</p>	MB45	<p>Frequency</p>

Notes

¹ See “Current Conversion Resistor” on page 2-17 for instructions on installing the resistor.

Table 2-3. MB Series Input Module Wiring Diagrams: STA-MB

Modules	Signal Wiring Diagram	Modules	Signal Wiring Diagram
MB30 MB31 MB40 MB41		MB37 MB47	
MB32 ¹		MB38 full-bridge	

Table 2-3. MB Series Input Module Wiring Diagrams: STA-MB (cont.)

Modules	Signal Wiring Diagram	Modules	Signal Wiring Diagram
MB34		MB38 half-bridge	<p style="text-align: center;">Strain Gauge</p>
MB36		MB45	<p style="text-align: center;">Frequency</p>

Notes

¹ See “Current Conversion Resistor” on page 2-17 for instructions on installing the resistor.

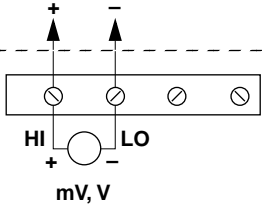
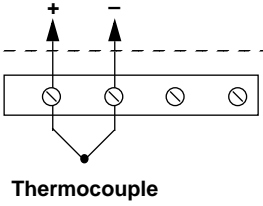
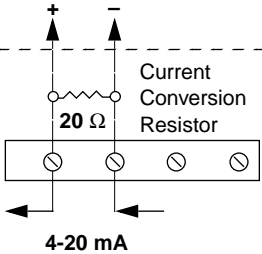
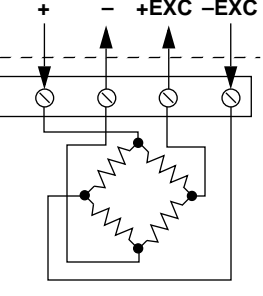
**Table 2-4. MB Series Output Module Wiring Diagram:
MB01, MB02, MB03, MB04, MB05, STA-1360**

Module	Wiring Diagram
MB39	

Table 2-5. MB Series Output Module Wiring Diagram: STA-MB

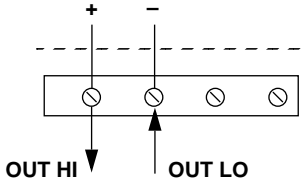
Module	Wiring Diagram
MB39	

Current Conversion Resistor

The MB32 comes with an external 20 Ω current conversion resistor. This resistor is mounted externally because the module cannot protect it from being destroyed by an accidental connection to the power line. For all backplanes except the MB04, mount the resistor in the socket located behind the signal terminal block as shown in Figure 2-10. For the MB04, mount the resistor in the socket in front of the signal terminal block.

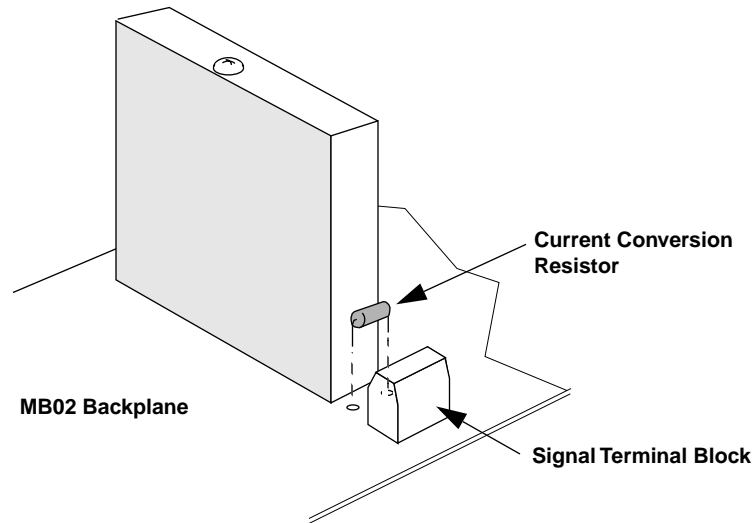

Figure 2-10. Installing the Current Conversion Resistor (MB01, MB02, MB03, MB05, STA-1360, STA-MB)

Connecting Backplanes to Keithley MetraByte Analog I/O Boards

This section tells how to connect MB Series backplanes to popular Keithley MetraByte analog I/O boards. The cabling and addressing scheme you use depends on both the backplane model and the analog board model. Once you have read the introductory sections, refer to the section for your specific combination; if information for your board is not here, refer to the user's guide for your board.

Configuring for Single-Ended Operation

Many Keithley MetraByte analog boards can be configured to accept either differential or single-ended inputs. In a single-ended configuration, all input voltages are compared to a common reference ground. In a differential configuration, each signal voltage input is paired with its own reference voltage.

When using MB Series modules with a Keithley MetraByte analog board, make sure that the analog I/O board is configured for single-ended operation. On a Keithley analog I/O board that offer both options, you typically use a slide switch to set the number of channels to 8 (differential) or 16 (single-ended). Consult the user's guide for your Keithley MetraByte analog I/O board to determine the exact method.

Connecting MB01 and MB05 Backplanes

The MB01 backplane supports up to 16 I/O channels per analog board; the MB05 backplane supports up to 8 I/O channels per analog board. Since they provide dedicated (non-multiplexed) channel-to-channel data transfer, the MB01 and MB05 are well-suited for high-speed, high-resolution applications.

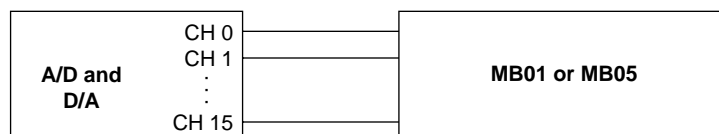

Figure 2-11. Typical MB01 or MB05 Application

Caution: When connecting a cable to the MB01 or MB05 backplane, make sure that you match pin 1 on the cable connector to pin 1 on the backplane connector. Otherwise the connection will not work.

Figure 2-12 shows the location of pin 1 on the MB01 or MB05 connectors.

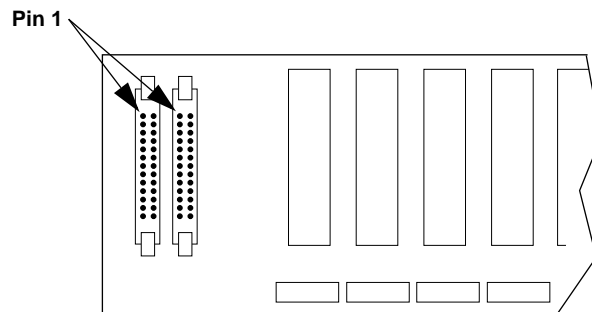

Figure 2-12. Location of Pin 1 on MB01 or MB05 Connectors

Connecting the MB01/MB05 to the DAS4, DAS-8, and DAS-800 Series

The following discussion refers to the following analog boards: DAS-4, DAS-8, DAS-8PGA, DAS-8/A0, μ CDAS-8PGA, and DAS-800 Series 8-channel analog input boards.

Use the C-8MB1 cable to connect the DAS board to the MB01 or MB05 backplane. This cable connects MB01/MB05 channels 0 through 7 to analog input channels 0 through 7 on the DAS board. Refer to Figure 2-13 for a cabling diagram.

The channel connections are single-ended. Make sure that the DAS board is set for single-ended operation.

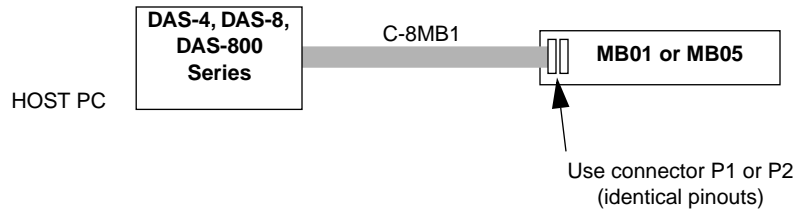

Figure 2-13. Connecting the DAS-4, DAS-8, or DAS-800 Series to the MB01/MB05

Connecting the MB01/MB05 to the DAS-16, DAS-1200, DAS-1400, and DAS-1600 Series

The following discussion refers to the following analog boards: DAS-16, DAS-16F, DAS-16G, μ CDAS-16G, DAS-1200 Series, DAS-1400 Series, and DAS-1600 Series boards.

Use the C-16MB1 cable to connect the DAS board to the MB01 or MB05 backplane. This cable connects MB01 channels 0 through 15 to analog input channels 0 through 15 on the DAS board or connects MB05 channels 0 through 7 to analog input channels 0 through 7 on the DAS board. Refer to Figure 2-14 for a cabling diagram.

The channel connections are single-ended. Make sure that the DAS board is set for 16-channel, single-ended operation.

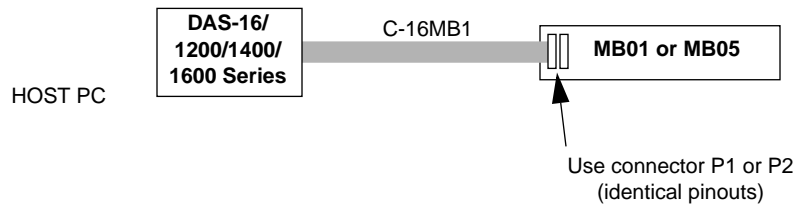

Figure 2-14. Connecting the DAS-16, DAS-1200, DAS-1400, or DAS-1600 Series to the MB01/MB05

Connecting the MB01/MB05 to the DAS-1800 Series

A DAS-1800ST/HR/AO Series board accepts one MB01 or MB05 backplane through an STA-1800U accessory. Cabling for attaching an MB01 backplane to an STA-1800U is shown in Figure 2-15. Refer to the user's guide for your DAS board for more information.

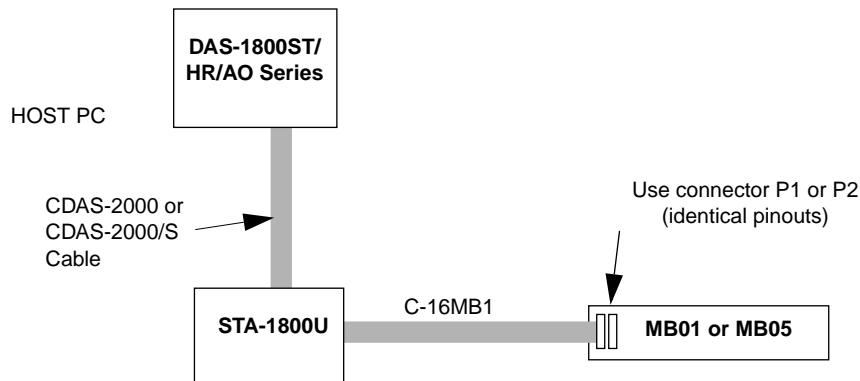

Figure 2-15. Connecting the DAS-1800ST/HR/AO Series to the MB01/MB05 using an STA-1800U

You can connect up to two MB01/MB05 backplanes to an STA-1800HC or up to four MB01/MB05 backplanes to CONN-1800HC of an DAS-1800HC Series board, as shown in Figure 2-16. Refer to the *DAS-1800HC Series User's Guide* for more information.

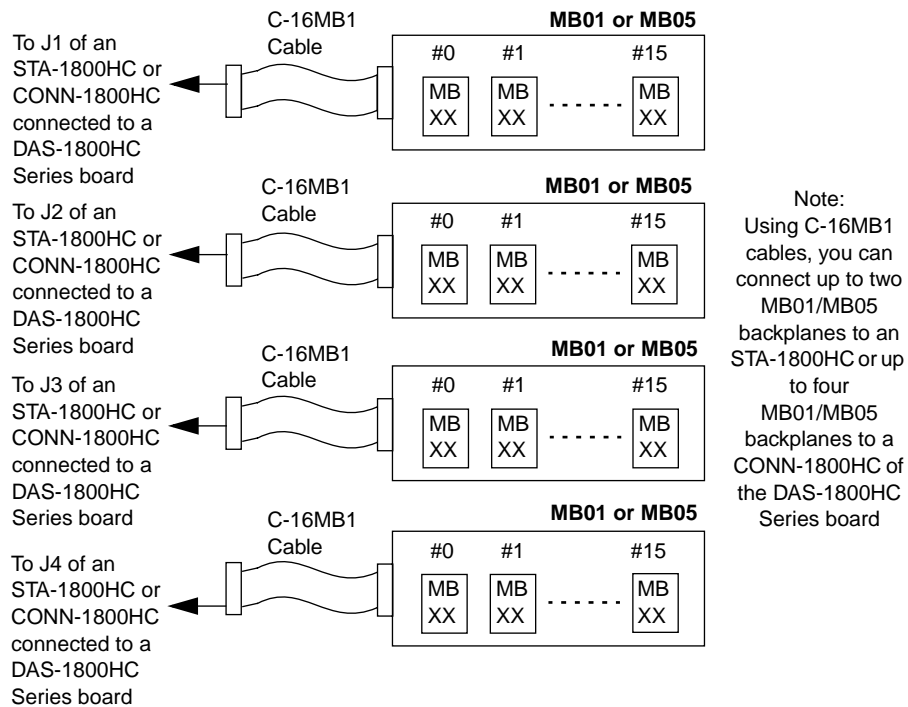

Figure 2-16. Connecting the DAS-1800HC Series to the MB01/MB05 using the STA-1800HC or CONN-1800HC

Caution: If you are programming an application requiring references to channel numbering on connectors J1 to J4 of an STA-1800HC or CONN-1800HC, you can obtain the correct channel numbering from the pin assignments for these connectors, as described in Appendix B of the *DAS-1800HC Series User's Guide*.

Connecting the MB01/MB05 to the DASCard-1000 Series

A DASCard-1000 Series board accepts one MB01/MB05 backplane through an STA-U accessory. Cabling for attaching an MB01/MB05 backplane to an STA-U is shown in Figure 2-17. Refer to the *DASCard-1000 Series User's Guide* for more information.

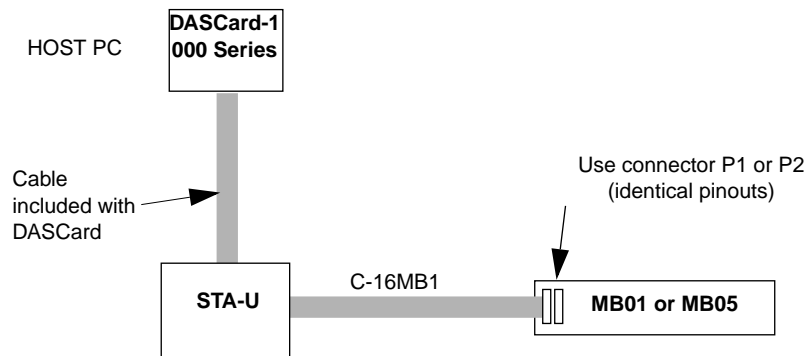

Figure 2-17. Connecting the DASCARD-1000 Series to the MB01/MB05 using an STA-U

Connecting the MB01/MB05 to the DAS-20

Use the C-20MB1 cable to connect the DAS-20 analog board to the MB01 or MB05 backplane. This cable connects MB01 channels 0 through 15 to DAS-20 analog input channels 0 through 15 or connects MB05 channels 0 through 7 to DAS-20 analog input channels 0 through 7. Refer to Figure 2-18 for a cabling diagram.

The channel connections are single-ended. Make sure that the DAS-20 is set for 16-channel, single-ended operation.

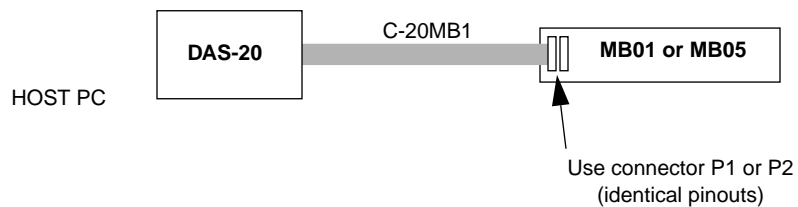

Figure 2-18. Connecting the DAS-20 to the MB01/MB05

Connecting MB02 Backplanes

You can connect up to four MB02 backplanes to one analog board to provide a total of 64 channels. Therefore, the MB02 is well-suited for larger systems or where the number of analog board channels is limited.

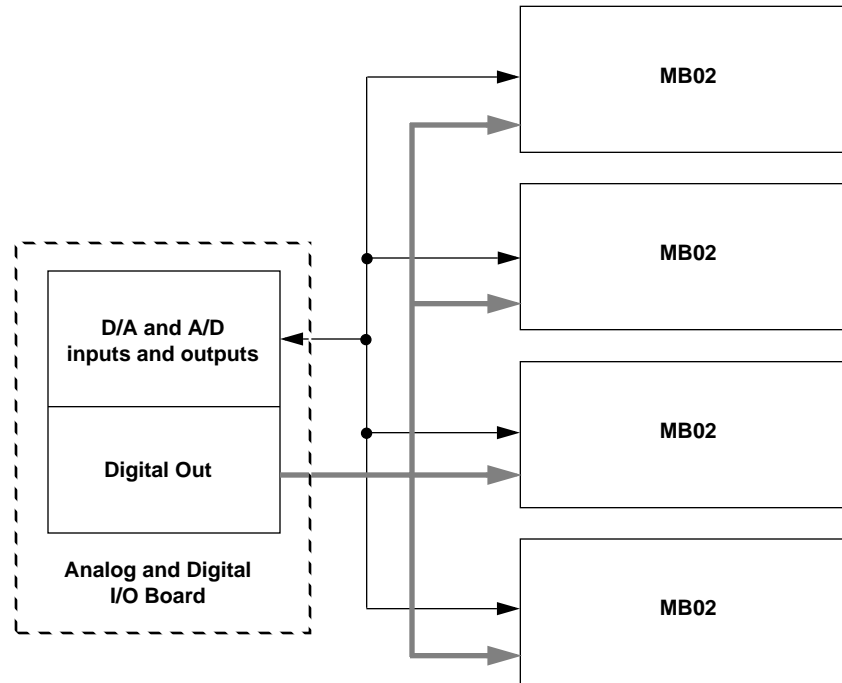

Figure 2-19. Typical MB02 Application

Caution: When connecting a cable to the MB02 backplane, make sure that you match pin 1 on the cable connector to pin 1 on the backplane connector. Otherwise the connection will not work.

Figure 2-20 shows the location of pin 1 on the MB02 connector.

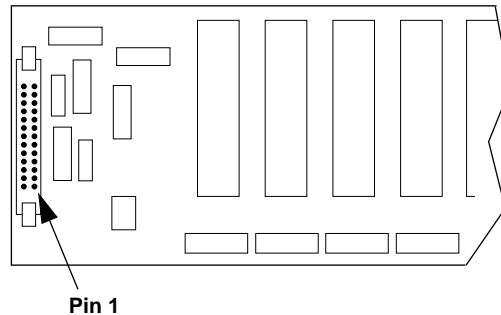

Figure 2-20. Location of Pin 1 on the MB02 Connector

Connecting the MB02 to the DAS4, DAS-8, and DAS-800 Series

The following discussion refers to the following analog boards: DAS-4, DAS-8, DAS-8PGA, DAS-8/A0, μ CDAS-8PGA, and DAS-800 Series.

Figure 2-21 shows how to connect the DAS board to up to four MB02 backplanes. The STA-SCM8 interface board connects one MB02 board to one analog input channel on the DAS board. One C-2600 cable connects each MB02 to the STA-SCM8, and the C-1800 cable connects the STA-SCM8 to the DAS board. The channel connections are single-ended; therefore, make sure that the DAS board is set for single-ended operation.

The four digital output lines on the DAS board select one of the 16 MB02 channels. For example, if you set the digital output lines on the DAS board to 1000 (8 decimal), MB02 channel 8 is selected on all four backplanes. DAS board channels 0 to 3 map directly to the connectors labeled 0 to 3 on the STA-SCM8. Figure 2-22 shows how the STA-SCM8 maps to the DAS board and MB02 interfaces.

The diskette that ships with the MB02 includes example programs for DAS board/MB02 applications.

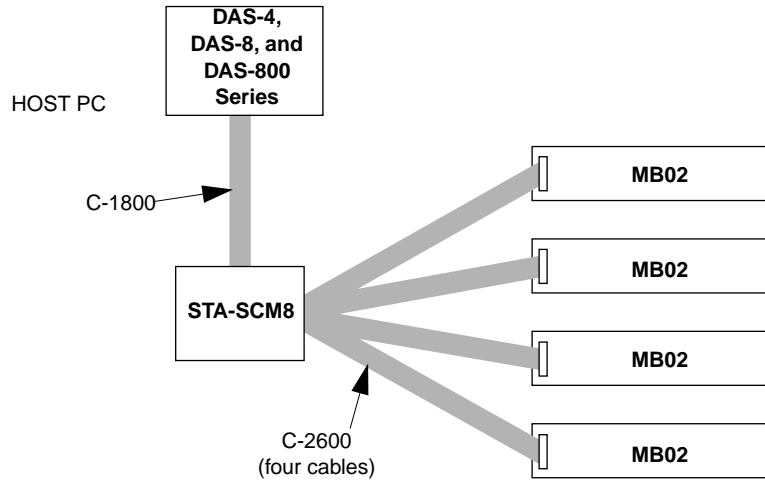

Figure 2-21. Connecting the DAS-4, DAS-8, or DAS-800 Series to the MB02

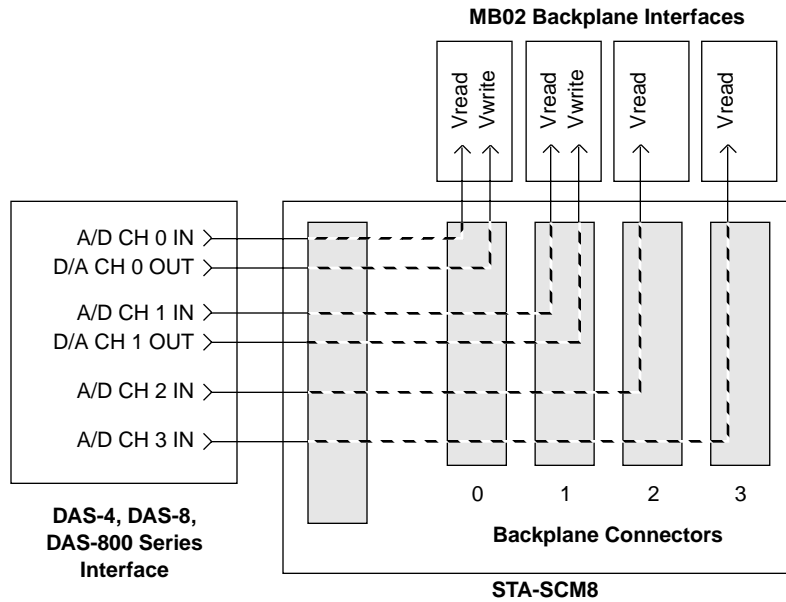

Figure 2-22. Connecting the DAS-4, DAS-8, or DAS-800 Series to the MB02 using the STA-SCM8

Connecting the MB02 to the DAS-16, DAS-1200, DAS-1400, and DAS-1600 Series

The following discussion refers to the following analog boards: DAS-16, DAS-16F, DAS-16G, μ CDAS-16G, DAS-1200 Series, DAS-1400 Series, and DAS-1600 Series.

Figure 2-23 shows how to connect a DAS board to up to four MB02 backplanes. The STA-SCM16 interface board connects one MB02 board to one analog input channel on the DAS board. One C-2600 cable connects each MB02 to the STA-SCM16, and the C-1800 cable connects the STA-SCM16 to the DAS board. The channel connections are single-ended; therefore, make sure that the analog board is set for single-ended, 16-channel operation.

The four digital output lines on the DAS board select one of the 16 MB02 channels. For example, if you set the digital output lines on the DAS board to 1000 (8 decimal), MB02 channel 8 is selected on all four backplanes. Analog input channels 0 to 3 on the DAS board map directly to the connectors labeled 0 to 3 on the STA-SCM16. Figure 2-24 shows how the STA-SCM16 maps to the DAS board and MB02 interfaces.

The diskette that ships with the MB02 includes example-only programs for DAS board/MB02 applications.

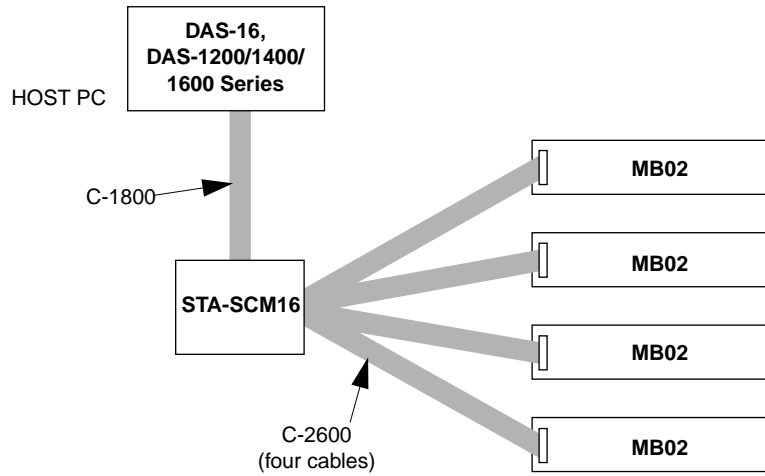

Figure 2-23. Connecting the DAS-16 or DAS-1200/1400/1600 Series to the MB02

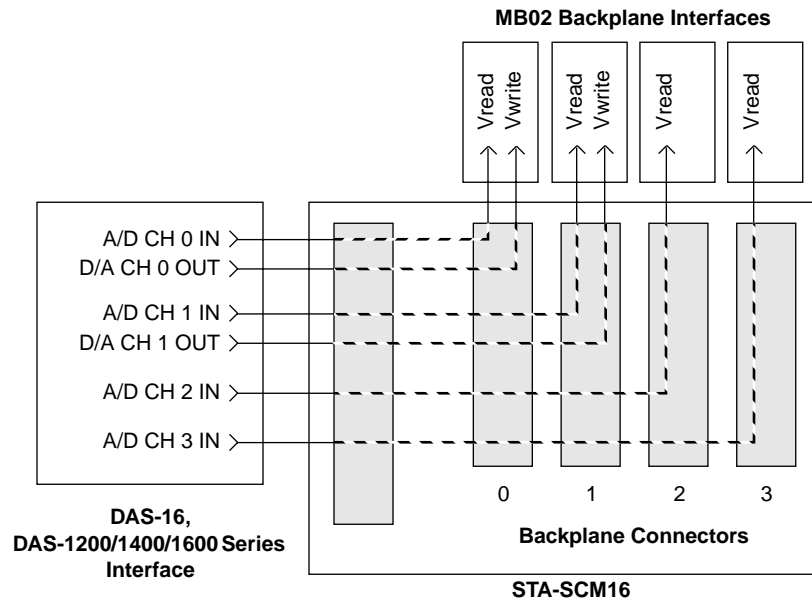

Figure 2-24. Connecting the DAS-16 or DAS-1200/1400/1600 Series to the MB02 using the STA-SCM16

Connecting the MB02 to the DAS-1800 Series

DAS-1800ST/HR/AO Series boards configured for single-ended inputs and working through multiple STA-1800U accessories can support up to 16 MB02 backplanes. A single STA-1800U contains receptacles (J4 to J7) for up to four MB02 backplane cables. Cabling for the four MB02 backplanes attached to an STA-1800U accessory is shown in Figure 2-25.

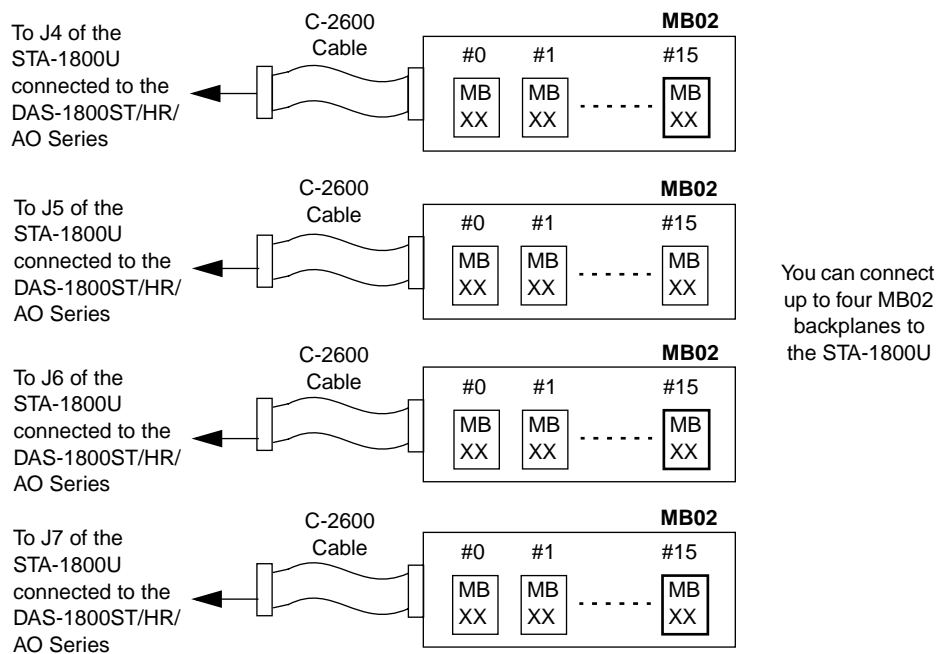

Figure 2-25. Connecting the DAS-1800ST/HR/AO Series to the MB02 using an STA-1800U

Use one STA-1800U for every four MB02 backplanes. Additional STA-1800U accessories are daisy-chained to the first STA-1800U, using CACC-2000 cables to connect J2 of one STA-1800U to J1 of the next, as shown in Figure 2-26.

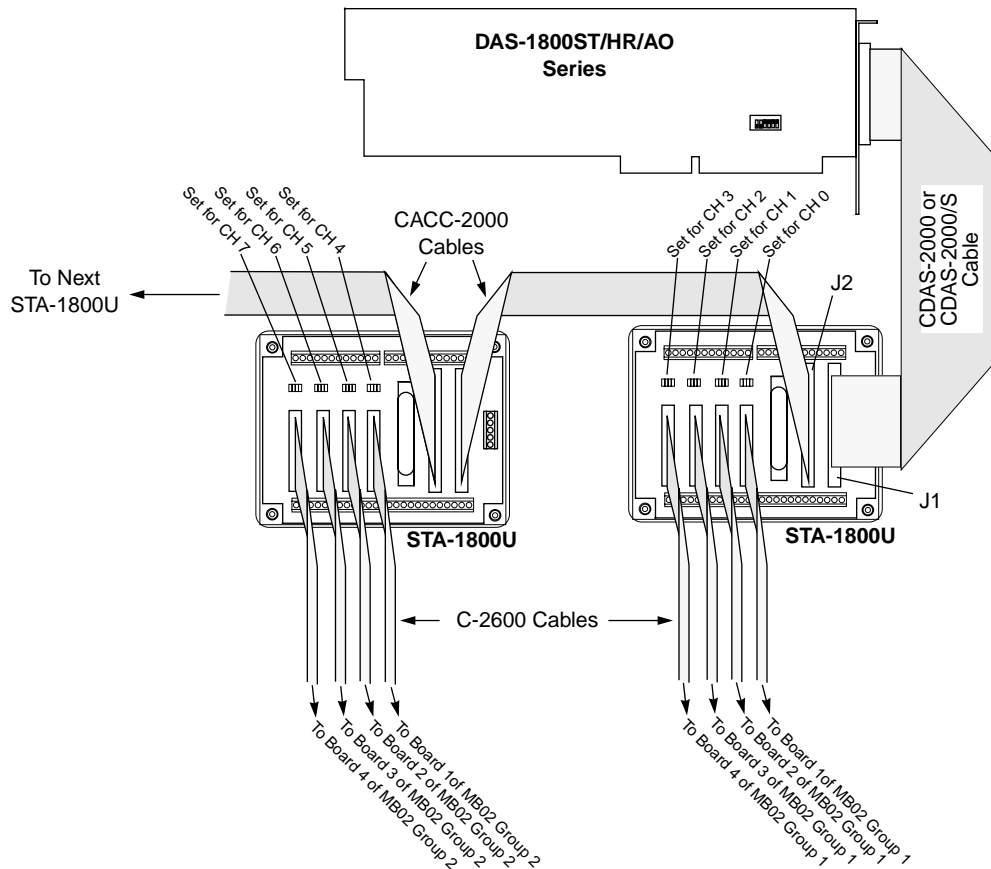

Figure 2-26. Daisy-Chaining STA-1800U Accessories with MB02 Backplanes

The jumper pad beside each STA-1800U receptacle (J4 to J7) selects the channel of a DAS-1800ST/HR/AO Series board that the attached MB02 backplane uses. On the first STA-1800U, the jumpers connect STA-1800U receptacles J4 to J7 to DAS-1800ST/HR/AO channels 0 to 3, respectively (default settings), as shown in the diagram. On a second STA-1800U, you position the jumpers to connect receptacles J4 to J7 to channels 4 to 7, respectively; and so on. Refer to Appendix B of the DAS board user's guide, for a diagram of receptacles J4 to J7 and their associated jumper pads.

Connecting the MB02 to the DAS-20

Figure 2-27 shows how to connect the DAS-20 to up to four MB02 backplanes. One CDAS-2000 cable connects the STA-20 to the DAS-20. The four MB02s are daisy-chained with C-2600 cables.

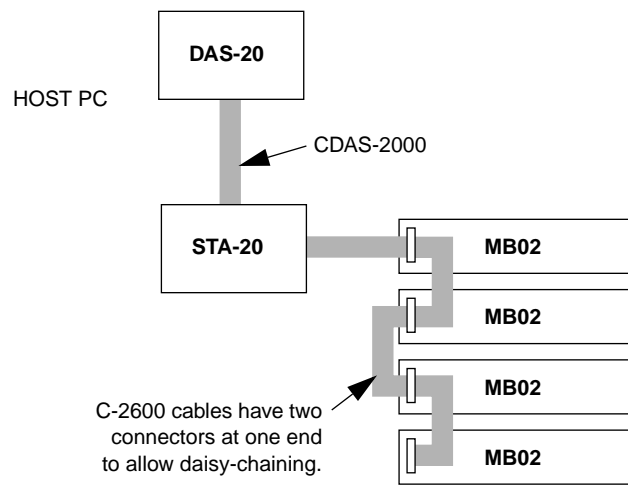

Figure 2-27. Connecting the DAS-20 to the MB02

Digital output lines 0 to 5 on the DAS-20 select one of the 64 MB02 channels (4 backplanes x 16 channels = 64 channels total). For example, if you set the DAS-20 digital output lines to 101000 (40 decimal), MB02 channel 40 is selected. All MB02 channels are multiplexed into channel 0 on the DAS-20.

The channel connections are single-ended; therefore, make sure that switches and jumpers are set as follows:

- DAS-20 is set for 16-channel operation.
- STA-20 DIFF/SE jumper is set to SE.
- MB02 address jumpers are set to assign a unique block of 16 addresses to each MB02, described next.

DAS-20 digital output lines 0 to 5 select one of the 64 channels on the four MB02 backplanes. You must set the address jumpers on the MB02s so that each one has a set of 16 unique addresses. Figure 2-28 shows the location of the address jumper blocks.

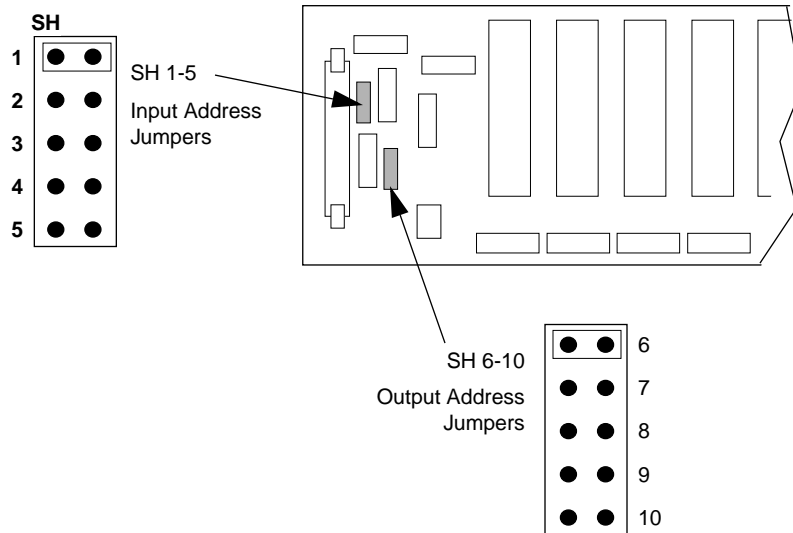

Figure 2-28. MB02 Address Jumper Locations

Jumpers SH1-5 set input (read) addresses and jumpers SH6-10 set output (write) addresses. Table 2-6 shows the address ranges selected by each jumper setting. Backplanes are factory configured with jumpers at positions 1 and 6. This sets up the backplane as a single-backplane, 16-channel system.

Table 2-6. MB02 Address Selection Jumpers

Input Jumper	Output Jumper	Range
1	6	stand-alone
2	7	48-63
3	8	32-47
4	9	16-31
5	10	0-15

The following example shows how the address jumpers are used in a multi-backplane setup. In this example, all four MB02 backplanes are used for signal inputs.

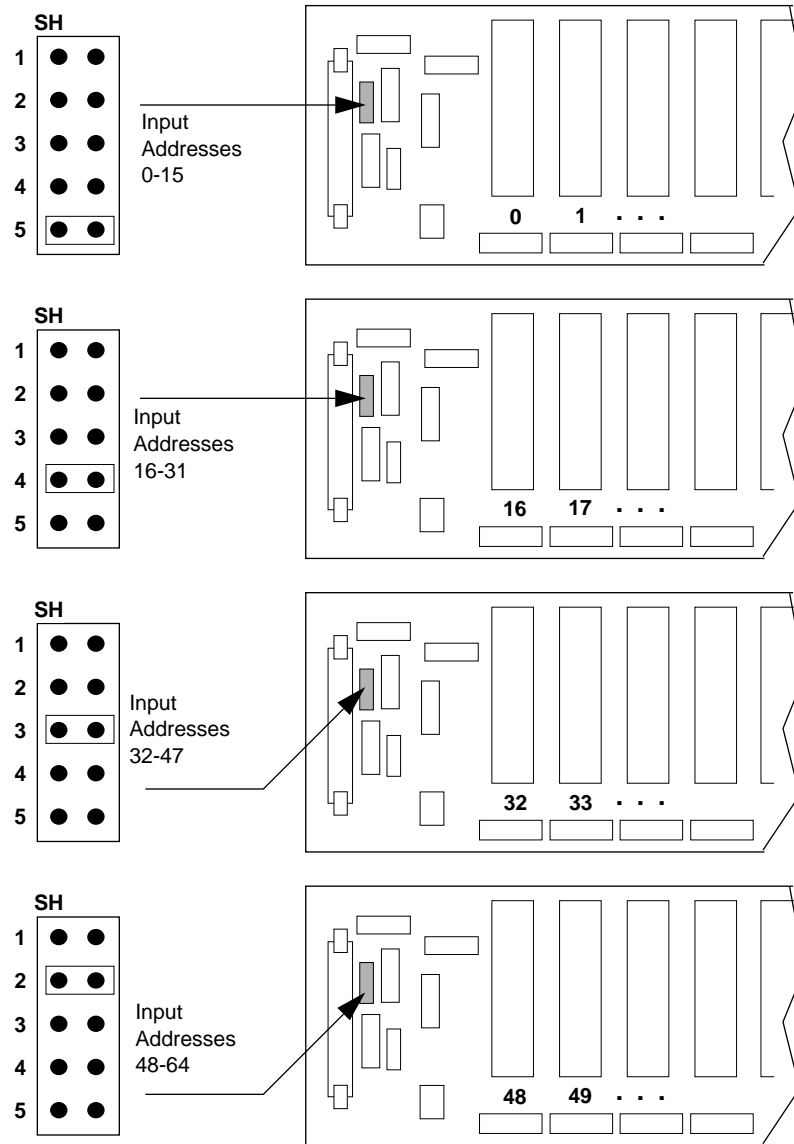

Figure 2-29. MB02 Address Jumper Example

Connecting MB03, MB04, and STA-1360 Backplanes

The MB03, MB04, and STA-1360 backplanes provide screw terminal outputs. To connect these backplanes to a Keithley MetraByte analog I/O board, you must wire the outputs to an accessory board that connects screw terminal inputs to the appropriate connector for your analog board. For example, the STC-37 connects screw terminal inputs to a 37-pin D-connector.

Connecting STA-MB Backplanes

On the STA-MB backplane, the inputs and outputs of four MB Series modules, as well as all 37 I/O connector pins, are brought out to screw terminals. You can connect the input or output of any module to any pin on the I/O connector by wiring the appropriate screw terminals together. This allows you to add up to four channels of signal-conditioned I/O to your system.

A module input or output travels to the DAS board through the following path, which you can trace in Figure 2-30:

- Module input/output pin to module input/output screw terminal through the STA-MB backplane
- Module input/output screw terminal to I/O connector screw terminal through a user-installed wire; refer to the next subsection for information on installing this wire.
- I/O connector screw terminal to I/O connector pin through the STA-MB backplane
- I/O connector pin to DAS board through the cable

Wiring Module Inputs and Outputs to the DAS Board

The following procedure tells how to wire a module input or output to a specific DAS board I/O connector pin. Repeat for each connection.

1. Using the I/O connector pinout in your DAS board manual, determine the number of the pin you want to connect to the module input or output.

2. On the STA-MB, find the screw terminal with the same number.
3. Wire this screw terminal to the desired module input or output screw terminal.

Figure 2-30 shows an example in which the Channel 0 module output is wired to screw terminal 37. This connects to pin 37 on the I/O connector, which is CH0 HI IN on a DAS-1600 Series board.

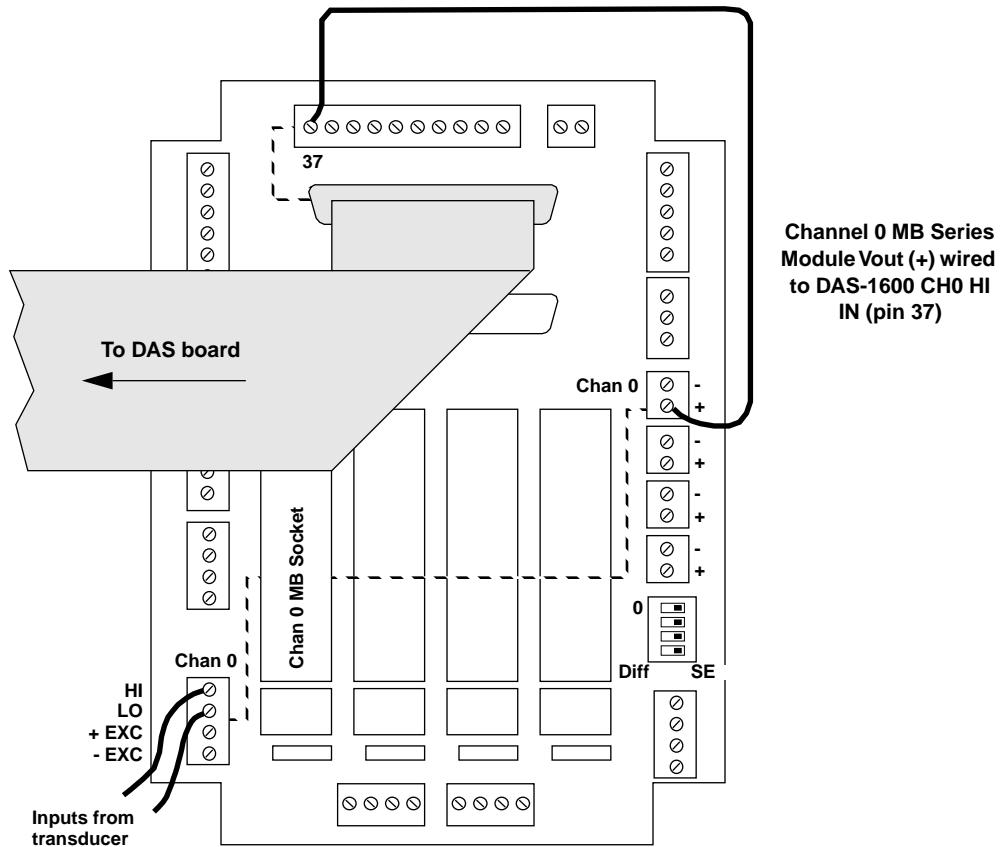

Figure 2-30. STA-MB/DAS-1600 Series Wiring Example

Setting STA-MB Single-Ended/Differential Switches

The STA-MB provides a set of DIP switches that lets you select either a single-ended or differential output configuration for each module. The single-ended setting (SE) grounds the low (-) output for the selected module so that only the high (+) output need be wired to the screw terminal input. Figure 2-31 shows the DIP switches set for single-ended operation on all channels.

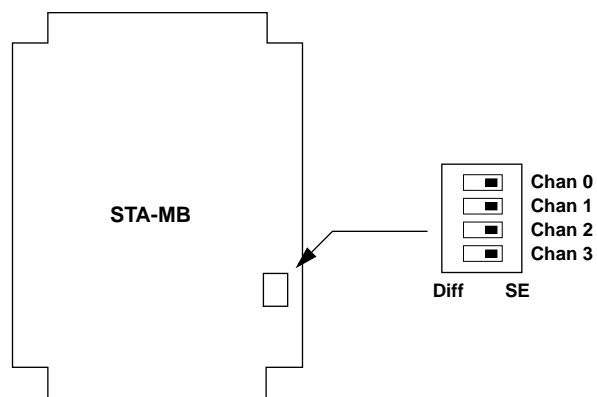

Figure 2-31. STA-MB Single-Ended/Differential Switches

Cabling to the STA-MB

This section describes some common cabling arrangements in systems using a DAS board and an STA-MB. Many possible arrangements exist. If you are unsure of how to cable your system, contact Keithley's Applications Engineering Department at (508) 880-3000 between 8:00 AM and 6:00 PM EST, Monday through Friday.

Figure 2-32 shows a DAS-800 Series board connected directly to an STA-MB using the C-1800 cable.

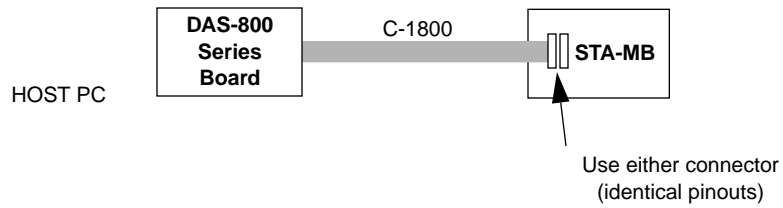

Figure 2-32. Connecting the DAS-800 Series to the STA-MB

Figure 2-33 shows a DAS-8 board connected to an EXP-16, which is daisy-chained to an STA-MB using two C-1800 cables.

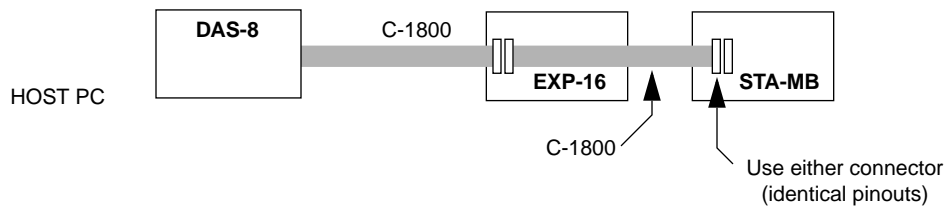

Figure 2-33. Connecting the DAS-8 to the STA-MB using an EXP-16

Figure 2-34 shows a DAS-800 Series board connected to an EXP-800, which is daisy-chained to an STA-MB using a CAB-3740 and C-1800 cable.

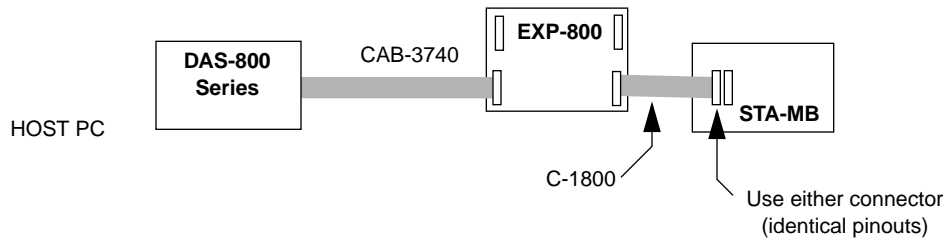

Figure 2-34. Connecting the DAS-800 Series to the STA-MB using an EXP-800

Figure 2-35 shows a DAS-1400/1200/1600 Series board or DASCARD-1000 Series card connected to an EXP-1600, which is daisy-chained to an STA-MB using a CAB-3740 and C-1800 cable.

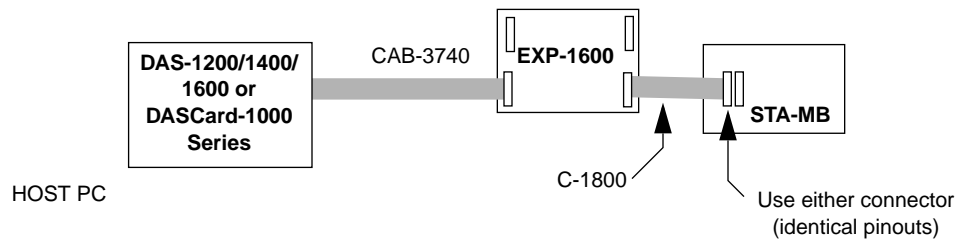

Figure 2-35. Connecting the DAS-1200/1400/1600 or DASCARD-1000 Series to the STA-MB using an EXP-1600

3

MB Series Module Descriptions

This chapter contains descriptions, specifications, functional block diagrams, input field connection diagrams, and ordering information for all MB Series modules. It includes the following sections:

- MB30 and MB31 millivolt and voltage input modules
- MB32 current input module
- MB34 RTD input module
- MB36 potentiometer input modules
- MB37 thermocouple input module
- MB38 strain gauge input module
- MB39 current output module
- MB40 and MB41 wide bandwidth millivolt volt input modules
- MB45 frequency input modules
- MB47 linearized thermocouple input module
- MBAF Series active low-pass filter modules

MB30 and MB31 Millivolt and Voltage Input Modules

The MB30 millivolt input module accepts ± 5 to ± 100 mV input signals and provides either a -5 V to $+5$ V or 0 to $+5$ V output. The MB31 voltage input module accepts ± 1 V to ± 40 V input signals and provides either a -5 V to $+5$ V or 0 to $+5$ V output.

Figure 3-1 on page 3-3 is a functional block diagram for the MB30 and MB31. A protection circuit assures safe operation even if a 240 V_{rms} power line is connected to the input screw terminals, and, in the MB31, the input signal is attenuated by a factor of 20 at this point. A three-pole filter with a 4 Hz cutoff provides 60 dB of NMR (Normal-Mode Rejection) and CMR enhancement at 60 Hz. (One pole of this filter is located at the module input, while the other two poles are in the output stage for optimum noise performance). A chopper-stabilized input amplifier provides all of the module's gain and assures low drift. This amplifier operates on the input signal after subtraction of a stable, laser-trimmed voltage, which sets the zero-scale input value. It is possible to suppress a zero-scale input that is many times the total span to provide precise expanded scale measurements.

Signal isolation is provided by transformer coupling using a proprietary modulation technique for linear, stable performance. A demodulator on the output side of the signal transformer recovers the original signal, which is then filtered and buffered to provide a clean, low-impedance output. A series output switch is included to eliminate the need for external multiplexing in many applications. This switch has a low output resistance and is controlled by an active-low enable input. In cases where the output switch is not used, the enable input should be grounded to power common to turn on the switch, as it is on the MB01 and MB05 backplanes.

The single $+5$ V supply powers a clock oscillator, which drives power transformers for the input and output circuits. The input circuit is, of course, fully floating. In addition, the output section acts as a third floating port, eliminating many problems that might be created by ground loops and supply noise. However, the common-mode range of the output circuit is limited: output common must be kept within ± 3 V of power common.

Note: A current path to insure that the voltage from power common to output common remains within ± 3 V must exist for proper operation of the demodulator and output switch.

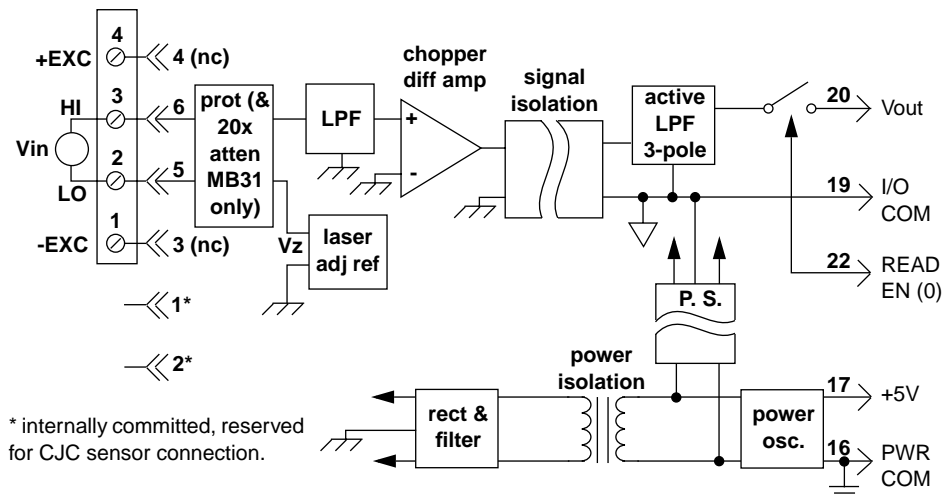

Figure 3-1. MB30 and MB31 Functional Block Diagram

Table 3-1 lists the specifications for the MB30 and MB31 modules. Note that specifications are typical at 25°C and +5 V and are subject to change without notice. Table 3-2 lists the ordering information for the MB30 and MB31 modules.

Table 3-1. MB30 and MB31 Specifications

Specification	MB30	MB31
Input Span Limits	±5 mV to ±100 mV	±1 V to ±40 V
Output Ranges	-5 V to +5 V or 0 to +5 V	-5 V to +5 V or 0 to +5 V
Accuracy ^{1,2}	±0.05% span ±10 µV RTI ±0.05% (V _Z)	±0.05% span ±0.2 mV RTI ±0.05% (V _Z)
Nonlinearity	±0.02% span	±0.02% span
Stability vs. Ambient Temperature Input Offset Output Offset Gain	±1 µV/°C ±20 µV/°C ±25 ppm of reading/°C	±20 µV/°C ±20 µV/°C ±50 ppm of reading/°C
Input Bias Current	±3 nA	±0.2 nA
Input Resistance Normal Power Off Overload	5 MΩ 40 kΩ 40 kΩ	650 kΩ 650 kΩ 650 kΩ
Noise Input, 0.1-10 Hz Output, 100 kHz	0.2 µV _{rms} RTI 200 µV _{rms} RTO	2 µV _{rms} RTI 200 µV _{rms} RTO
Bandwidth, -3 dB	4 Hz	4 Hz
Rise Time, 10% to 90% Span	0.2 s	0.2 s
CMV, Input to Output Continuous Transient	1500 V _{rms} max meets IEEE-STD 472 (SWC)	1500 V _{rms} max meets IEEE-STD 472 (SWC)
CMR (50 or 60 Hz) 1 kΩ in Either or Both Input Leads	160 dB (all ranges)	160 dB (span < ±2 V) 150 dB (span = ±10 V)
NMR (50 or 60 Hz)	60 dB	60 dB
Input Protection Continuous Transient	240 V _{rms} max continuous meets IEEE-STD 472 (SWC)	240 V _{rms} max continuous meets IEEE-STD 472 (SWC)
Output Resistance ³	50 Ω	50 Ω
Voltage Output Protection	Continuous Short to Ground	Continuous Short to Ground

Table 3-1. MB30 and MB31 Specifications (cont.)

Specification	MB30	MB31
Output Selection Time	20 μ s	20 μ s
Output Selection Input Max Logic "0" Min Logic "1" Max Logic "1" Input Current "0"	+1 V +2.5 V +36 V 0.4 mA	+1 V +2.5 V +36 V 0.4 mA
Power Supply Voltage	+5 V \pm 5%	+5 V \pm 5%
Power Supply Sensitivity	\pm 2 μ V/Vs% (RTI)	\pm 0.4 mV/Vs% (RTI)
Power Consumption	150 mW (30 mA)	150 mW (30 mA)
Size	2.25" x 2.25" x 0.60" (52 mm x 52 mm x 15 mm)	2.25" x 2.25" x 0.60" (52 mm x 52 mm x 15 mm)
Environmental Temperature Range, Rated Performance Temperature Range, Operating Temperature Range, Storage Relative Humidity (MIL 202) RFI Susceptibility	-25°C to +85°C -40°C to +85°C -40°C to +85°C 0 to 95% @ 60°C noncondensing \pm 0.5% span error @ 400 MHz, 5 W, 3 feet	-25°C to +85°C -40°C to +85°C -40°C to +85°C 0 to 95% @ 60°C noncondensing \pm 0.5% span error @ 400 MHz, 5 W, 3 feet

Notes

- ¹ Includes the combined effects of repeatability, hysteresis, and nonlinearity and assumes very high load resistance.
- ² V_z is the nominal input voltage that results in a 0 V output.
- ³ The output resistance value can be used to determine gain error when the module is driving a resistive load. However, loads heavier than 20 k Ω will degrade nonlinearity and gain temperature coefficient.

Table 3-2. MB30 and MB31 Ordering Information

Input Range	Output Range	Model
-10 mV to +10 mV	-5 V to +5 V	MB30-01
-50 mV to +50 mV	-5 V to +5 V	MB30-02
-100 mV to +100 mV	-5 V to +5 V	MB30-03
-10 mV to +10 mV	0 to +5 V	MB30-04 ¹
-50 mV to +50 mV	0 to +5 V	MB30-05 ¹
-100 mV to +100 mV	0 to +5 V	MB30-06 ¹
-1 V to +1 V	-5 V to +5 V	MB31-01
-5 V to +5 V	-5 V to +5 V	MB31-02
-10 V to +10 V	-5 V to +5 V	MB31-03
-1 V to +1 V	0 to +5 V	MB31-04 ¹
-5 V to +5 V	0 to +5 V	MB31-05 ¹
-10 V to +10 V	0 to +5 V	MB31-06 ¹
-20 V to +20 V	-5 V to +5 V	MB31-07
-20 V to +20 V	0 to +5 V	MB31-08 ¹
-40 V to +40 V	-5 V to +5 V	MB31-09
-40 V to +40 V	0 to +5 V	MB31-10 ¹

Notes

¹ These ranges map bipolar input ranges into unipolar output ranges; 0 maps to +2.5 V.

MB32 Current Input Module

The MB32 current input module measures a 4-20 mA or 0-20 mA process current input signal by reading the voltage across a precision 20 Ω resistor. It provides a 0 to +5 V output signal.

Figure 3-2 on page 3-8 is a functional block diagram for the MB32. Since the resistor cannot be protected against destruction in the event of an inadvertent connection of the power line, it is provided in the form of a separate pluggable resistor carrier assembly. A protection circuit assures safe operation even if a 240 V_{rms} power line is connected to the input screw terminals. A three-pole filter with a 4 Hz cutoff provides 60 dB of NMR (Normal Mode Rejection) and CMR enhancement at 60 Hz. (One pole of this filter is located at the module input, while the other two poles are in the output stage for optimum noise performance.) A chopper-stabilized input amplifier provides all of the module's gain and assures low drift. This amplifier operates on the input signal after subtraction of a stable, laser-trimmed voltage, which sets the zero-scale input value for the 4-20 mA range.

Signal isolation is provided by transformer coupling using a proprietary modulation technique for linear, stable performance. A demodulator on the output side of the signal transformer recovers the original signal, which is then filtered and buffered to provide a clean, low-impedance output. A series output switch is included to eliminate the need for external multiplexing in many applications. This switch has a low output resistance and is controlled by an active-low enable input. In cases where the output switch is not used, the enable input should be grounded to power common to turn on the switch, as it is on the MB01 and MB05 backplanes.

The single +5 V supply powers a clock oscillator, which drives power transformers for the input and output circuits. The input circuit is, of course, fully floating. In addition, the output section acts as a third floating port, eliminating many problems that might be created by ground loops and supply noise. However, the common-mode range of the output circuit is limited: output common must be kept within ± 3 V of power common.

Note: A current path to insure that the voltage from power common to output common remains within ± 3 V must exist for proper operation of the demodulator and output switch.

The resistor is a 20 Ω , 0.1% (typical), 1/4 watt, 20 ppm/ $^{\circ}$ C resistor which is fully encapsulated. The resistor tolerance directly affects the performance of the data acquisition system and should be included in the worst case analysis of the system. It ships with the MB32 module.

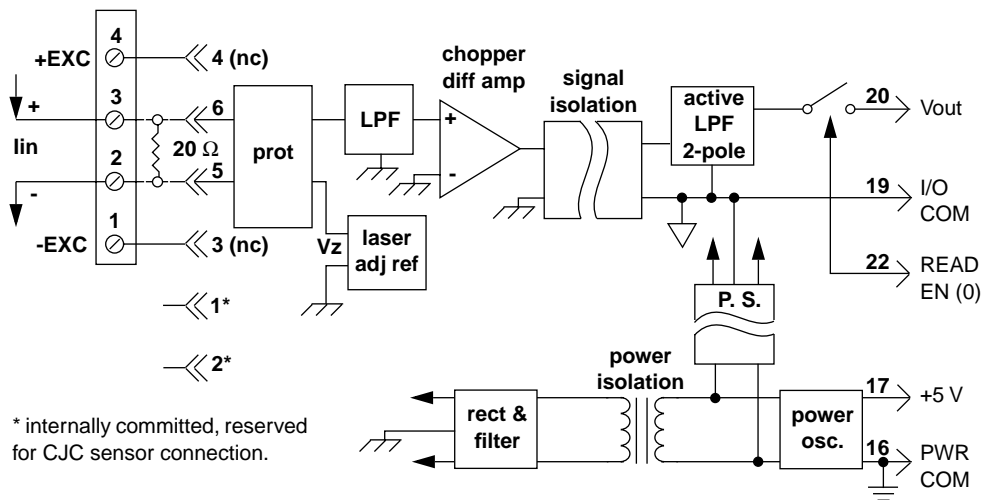

Figure 3-2. MB32 Functional Block Diagram

Table 3-3 lists the specifications for the MB32 module. Note that specifications are typical at 25 $^{\circ}$ C and +5 V and are subject to change without notice. Table 3-4 lists the ordering information for the MB32 module.

Table 3-3. MB32 Specifications

Specification	MB32
Input Ranges	0 to 20 mA, 4 to 20 mA
Output Range	0 to +5 V
Accuracy ^{1,2}	$\pm 0.05\%$ span $\pm 0.05\%$ (I_z)
Input Resistor ³ Value Accuracy	20.00 Ω $\pm 0.1\%$
Nonlinearity	$\pm 0.02\%$ span
Stability vs. Ambient Temperature Module Offset Module Gain	$\pm 0.0025\%/^{\circ}\text{C}$ of I_z $\pm 0.0025\%/^{\circ}\text{C}$ of reading/ $^{\circ}\text{C}$
Stability of Supplied Input Resistor	$\pm 0.001\%/^{\circ}\text{C}$
Noise Input, 0.1-10 Hz Output, 100 kHz	10 nA _{rms} RTI 200 μV _{rms} RTO
Bandwidth, -3 dB	4 Hz
Rise Time, 10% to 90% Span	0.2 s
CMV, Input to Output Continuous Transient	1500 V _{rms} max meets IEEE-STD 472 (SWC)
CMR (50 or 60 Hz) 1 k Ω in Either or Both Input Leads	160 dB (all ranges)
NMR (50 or 60 Hz)	60 dB
Input Protection Continuous Transient	240 V _{rms} max continuous meets IEEE-STD 472 (SWC)
Output Resistance ⁴	50 Ω
Voltage Output Protection	Continuous Short to Ground
Output Selection Time	20 μs

Table 3-3. MB32 Specifications (cont.)

Specification	MB32
Output Selection Input Max Logic "0" Min Logic "1" Max Logic "1" Input Current "0"	+1 V +2.5 V +36 V 0.4 mA
Power Supply Voltage	+5 V ±5%
Power Supply Sensitivity	±2 µV/Vs% (RTI)
Power Consumption	150 mW (30 mA)
Size	2.25" x 2.25" x 0.60" (52 mm x 52 mm x 15 mm)
Environmental Temperature Range, Rated Performance Temperature Range, Operating Temperature Range, Storage Relative Humidity (MIL 202) RFI Susceptibility	-25°C to +85°C -40°C to +85°C -40°C to +85°C 0 to 95% @ 60°C noncondensing ±0.5% span error @ 400 MHz, 5W, 3 feet

Notes

- ¹ Includes the combined effects of repeatability, hysteresis, and nonlinearity and assumes very high load resistance. Does not include input resistor error.
- ² I_z is the nominal value of input current which results in an output of 0 V.
- ³ The current-to-voltage conversion resistor is supplied as a plug-in component for mounting external to the module.
- ⁴ The output resistance value can be used to determine gain error when the module is driving a resistive load. However, loads heavier than 20 kΩ will degrade nonlinearity and gain temperature coefficient.

Table 3-4. MB32 Ordering Information

Input Range	Output Range	Model
4-20 mA	0 to +5 V	MB32-01
0-20 mA	0 to +5 V	MB32-02

MB34 RTD Input Module

The MB34 RTD input module accepts a wide variety of RTD types as inputs and provides a linearized output of 0 to +5 V.

Figure 3-3 on page 3-12 is a functional block diagram of the MB34. Excitation for the RTD is provided by a current source, with an identical current taken through the third RTD lead in such a way as to cancel the effects of (equal) lead resistances. The second current also flows in R_z , which is laser-trimmed to the value of the RTD at the temperature that is to result in a module output of zero volts. Thus, the input seen by the differential amplifier is zero at that scale point. Since both current sources are connected to input screw terminals, they are protected against accidental application of voltages up to 240 V_{rms}. A pair of protection networks serves the same function for the amplifier, and input filtering is provided at the same points.

The differential amplifier is a chopper-stabilized design featuring exceptionally low drift. This makes possible the use of very low RTD excitation currents to minimize self-heating without incurring any loss of accuracy. A feedback linearizer is laser-trimmed along with the module's gain and zero settings.

Signal isolation is provided by transformer coupling using a proprietary modulation technique for linear, stable performance. A demodulator on the output side of the signal transformer recovers the original signal, which is then filtered and buffered to provide a clean, low-impedance output. A series output switch is included to eliminate the need for external multiplexing in many applications. This switch has a low output resistance and is controlled by an active-low enable input. In cases where the output switch is not used, the enable input should be grounded to power common to turn on the switch, as it is on the MB01 and MB05 backplanes.

The single +5 V supply powers a clock oscillator, which drives power transformers for the input and output circuits. The input circuit is, of course, fully floating. In addition, the output section acts as a third floating port, eliminating many problems that might be created by ground loops and supply noise. However, the common-mode range of the output circuit is limited: output common must be kept within ± 3 V of power common.

Note: A current path to insure that the voltage from power common to output common remains within ± 3 V must exist for proper operation of the demodulator and output switch.

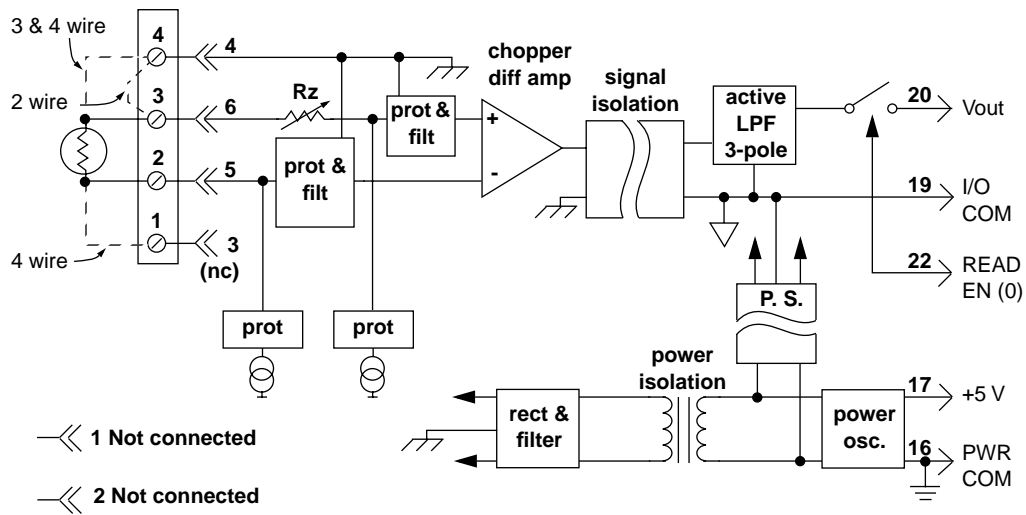

Figure 3-3. MB34 Functional Block Diagram

Table 3-5 lists the specifications for the MB34 module. Note that specifications are typical at 25°C and +5 V and are subject to change without notice. Table 3-6 lists the ordering information for the MB34 module.

Table 3-5. MB34 Specifications

Specification	MB34
Input Span Limits	25°C to 1070°C (100 Ω Pt)
Output Range	0 to +5 V
Accuracy ^{1,2,3}	±0.05% span ±0.1 Ω ±0.05% (R _Z)
Conformity Error ⁴	±0.05% span
Stability vs. Ambient Temperature Input Offset Output Offset Gain	±0.02°C/°C ±20 μV/°C ±50 ppm of reading/°C
Input Bias Current	±3 nA
Input Resistance Normal Power Off Overload	5 MΩ 40 kΩ 40 kΩ
Noise Input, 0.1-10 Hz Output, 100 kHz	0.2 μV _{rms} RTI 200 μV _{rms} RTO
Bandwidth, -3 dB	4 Hz
Rise Time, 10% to 90% Span	0.2 s
CMV, Input to Output Continuous Transient	1500 V _{rms} max meets IEEE-STD 472 (SWC)
CMR (50 or 60 Hz) 1 kΩ in Either or Both Input Leads	160 dB (all ranges)
NMR (50 or 60 Hz)	60 dB
Sensor Excitation Current 100 Ω Pt, 120 Ω Ni 10 Ω Cu	0.25 mA 1.0 mA
Lead Resistance Effect 100 Ω Pt, 120 Ω Ni 10 Ω Cu	±0.02°C/Ω ±0.2°C/Ω

Table 3-5. MB34 Specifications (cont.)

Specification	MB34
Input Protection Continuous	240 V _{rms} max continuous
Output Resistance ⁵	50 Ω
Voltage Output Protection	Continuous Short to Ground
Output Selection Time	20 μs
Output Selection Input Max Logic "0" Min Logic "1" Max Logic "1" Input Current "0"	+1 V +2.5 V +36 V 0.4 mA
Power Supply Voltage	+5 V ±5%
Power Supply Sensitivity 100 Ω Pt, 120 Ω Ni 10 Ω Cu	0.05°C/V 0.5°C/V
Power Consumption	150 mW (30 mA)
Size	2.25" x 2.25" x 0.60" (52 mm x 52 mm x 15 mm)
Environmental Temperature Range, Rated Performance Temperature Range, Operating Temperature Range, Storage Relative Humidity (MIL 202)	-25°C to +85°C -40°C to +85°C -40°C to +85°C 0 to 95% @ 60°C noncondensing

Notes

¹ ±0.025 W for 1 mA excitation used with Cu RTDs.

² R_z is the value of the RTD resistance at the lowest point of the measurement range.

³ Includes the combined effects of repeatability hysteresis, and linearity and assumes very high load resistance. Does not include sensor or signal source error.

⁴ For Pt RTDs only; other types may vary.

⁵ The output resistance value can be used to determine gain error when the module is driving a resistive load. Note, however, that loads heavier than 20 kΩ will also degrade nonlinearity and gain temperature coefficient.

Table 3-6. MB34 Ordering Information

Type	Input Range	Output Range	Model
100 Ω Pt, $\alpha = 0.00385$	-100°C to +100°C (-148°F to +212°F)	0 to +5 V	MB34-01
100 Ω Pt, $\alpha = 0.00385$	0 to +100°C (+32°F to 212°F)	0 to +5 V	MB34-02
100 Ω Pt, $\alpha = 0.00385$	0 to +200°C (+32°F to 392°F)	0 to +5 V	MB34-03
100 Ω Pt, $\alpha = 0.00385$	0 to +600°C (+32°F to 1112°F)	0 to +5 V	MB34-04
10 Ω Cu	0 to +120°C (10 Ω @ 0°C) (+32°F to +248°F)	0 to +5 V	MB34-C-01
10 Ω Cu	0 to +120°C (10 Ω @ 25°C) (+32°F to +248°F)	0 to +5 V	MB34-C-02
120 Ω Ni	0 to +300°C (+32°F to +572°F)	0 to +5 V	MB34-N-01

MB36 Potentiometer Input Module

The MB36 potentiometer input module provides a single channel of potentiometer input that is filtered, isolated, amplified, and converted to a high-level analog voltage output (0 to 5 V). The voltage output is logic-switch controlled, which allows this module to share a common analog bus without requiring external multiplexers.

Figure 3-4 on page 3-17 is a functional block diagram of the MB36.

The MB36 potentiometer input module contains a completely isolated computer-side circuit that you can float to ± 50 V from PWR COM, pin 16. Complete isolation means that no connection is required between I/O COM and PWR COM for proper operation of the output switch. If desired, you can turn on the output switch continuously by connecting pin 22, the READ EN pin, to I/O COM, pin 19.

Excitation for the potentiometer is provided from the module by two matched current sources. Using a three-wire potentiometer allows you to cancel the effects of lead resistances. The excitation currents are very small (less than 1.0 mA), which minimizes self-heating.

Signal filtering is accomplished with a six-pole filter that provides 95 dB of normal mode rejection at 60 Hz and 90 dB at 50 Hz. Two poles of this filter are on the field side of the isolation barrier and the other four poles are in the output stage. After the initial field-side filtering, the input signal is chopped by a proprietary chopper circuit. Isolation is provided by transformer coupling, which is implemented using a proprietary technique to suppress transmission of common mode spikes or surges.

The module is powered from +5 VDC, $\pm 5\%$. A special circuit in the module provides protection against accidental connection of power-line voltages up to 240 VAC.

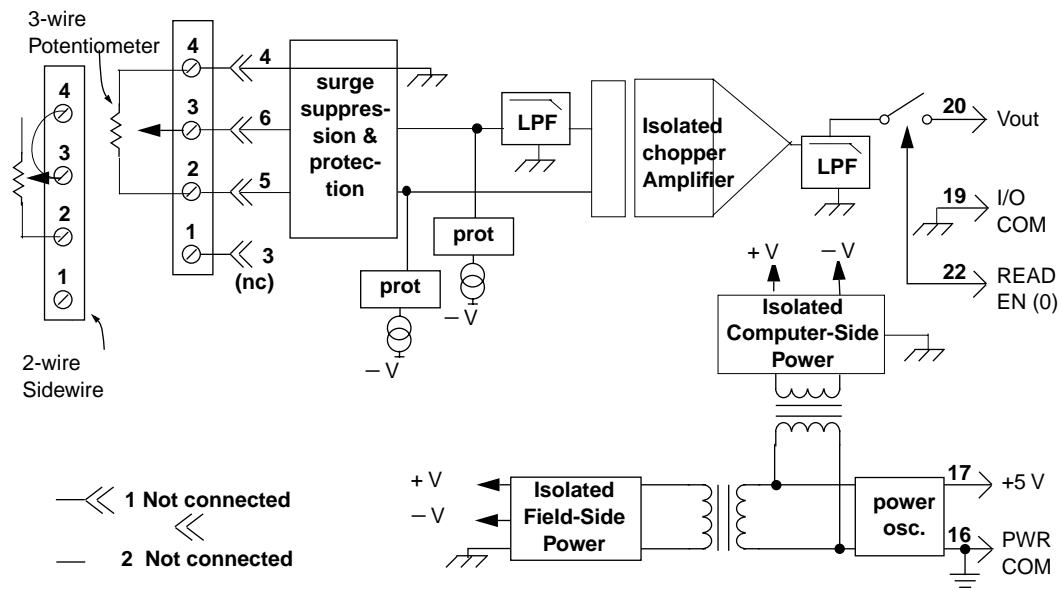

Figure 3-4. MB36 Functional Block Diagram

Table 3-5 lists the specifications for the MB36 module. Note that specifications are typical at 25°C and +5 V and are subject to change without notice. Table 3-6 lists the ordering information for the MB36 module.

Table 3-7. MB36 Specifications

Specification	MB36
Input Span Limits	0 to 10 k Ω
Output Range	0 to +5 V
Accuracy ¹	$\pm 0.08\%$ span
Stability vs. Ambient Temperature Input Offset Output Offset Gain	$\pm 0.004 \Omega/^{\circ}\text{C}$; 100 Ω , 500 Ω , 1 k Ω sensor $\pm 0.010 \Omega/^{\circ}\text{C}$; 10 k Ω sensor $\pm 20 \mu\text{V}/^{\circ}\text{C}$ $\pm 50 \text{ ppm of reading}/^{\circ}\text{C}$
Input Resistance Normal Power Off Overload	50 M Ω 40 k Ω 40 k Ω
Noise Input, 0.1-10 Hz Output, 100 kHz	$0.2 \mu\text{V}_{\text{rms}} \text{RTI}^2$ $200 \mu\text{V}_{\text{rms}} \text{RTO}^3$
Bandwidth, -3 dB	4 Hz
Response time, 90% span	0.2 s
CMV, Input to Output Continuous Transient	1500 V _{rms} max ANSI/IEEE C37.90.1-1989
CMR (50 or 60 Hz)	160 dB
NMR	95 dB at 60 Hz 90 dB at 50 Hz
Sensor Excitation Current 100 Ω , 500 Ω , 1 k Ω 10 k Ω	0.25 mA 0.10 mA
Lead Resistance Effect 100 Ω , 500 Ω , 1 k Ω 10 k Ω	$\pm 0.10 \Omega/\Omega$ $\pm 0.02 \Omega/\Omega$
Input Protection Continuous Transient	240 V _{rms} max continuous ANSI/IEEE C37.90.1-1989

Table 3-7. MB36 Specifications (cont.)

Specification	MB36
Output Resistance	50 Ω
Voltage Output Protection	Continuous Short to Ground
Output Selection Time (to 1 mV of V_{OUT})	6 μ s at $C_{LOAD} = 0$ to 2000 pF
Output Current Limit	14 mA maximum
Environmental Max Logic "0" Min Logic "1" Max Logic "1" Input Current "0, 1")	+0.8 V +2.4 V +3.6 V +0.5 μ A
Power Supply Voltage	+5 V \pm 5%
Power Supply Sensitivity	\pm 2 μ V/% RTI ¹
Power Supply Current	30 mA
Size	2.28" x 2.26" x 0.60" (58 mm x 57 mm x 15 mm)
Environmental Temperature Range, Rated Performance Temperature Range, Operating Temperature Range, Storage Relative Humidity (MIL 202)	-25°C to +85°C -40°C to +85°C -40°C to +85°C 0 to 95% @ 60°C noncondensing

Notes

¹ Includes nonlinearity, hysteresis, and repeatability.

² Referenced to input.

³ Referenced to output.

Table 3-8. MB36 Ordering Information

Input Range	Output Range	Model
0 to 100 Ω	0 to +5 V	MB36-01
0 to 500 Ω	0 to +5 V	MB36-02
0 to 1 k Ω	0 to +5 V	MB36-03
0 to 10 k Ω	0 to +5 V	MB36-04

MB37 Thermocouple Input Module

The MB37 thermocouple input module accepts input signals from types J, K, T, E, R, S, and B thermocouples and provides a 0 to +5 V output. Figure 3-5 on page 3-22 is a functional block diagram for the MB37.

Cold junction compensation circuitry corrects for the effects of the parasitic thermocouples formed by thermocouple wire connections to the input screw terminals. The compensator provides an accuracy of $\pm 0.5^{\circ}\text{C}$ over the $+5^{\circ}\text{C}$ to $+45^{\circ}\text{C}$ ambient temperature range. A bias current supplied through resistor R_{oc} gives a predictable upscale response to an open thermocouple. (Downscale open thermocouple detection can be provided by installing a 50 M Ω resistor across screw terminals 1 and 3. This resistor could be a 0.25 W carbon composition; $\pm 20\%$ tolerance is suitable.)

A protection circuit assures safe operation even if a 240 V_{rms} power line is connected to the input screw terminals. A three-pole filter with a 4 Hz cutoff provides 60 dB of NMR (Normal Mode Rejection) and CMR enhancement at 60 Hz. (One pole of this filter is located at the module input, while the other two poles are in the output stage for optimum noise performance.) A chopper-stabilized input amplifier provides all of the module's gain and assures low drift. This amplifier operates on the input signal after subtraction of a stable, laser-trimmed voltage, which sets the zero-scale input value. Therefore, it is possible to suppress a zero-scale input that is many times the total span to provide precise expanded scale measurements.

Signal isolation is provided by transformer coupling using a proprietary modulation technique for linear, stable performance. A demodulator on the output side of the signal transformer recovers the original signal, which is then filtered and buffered to provide a clean, low-impedance output. A series output switch is included to eliminate the need for external multiplexing in many applications. This switch has a low output resistance and is controlled by an active-low enable input. In cases where the output switch is not used, the enable input should be grounded to power common to turn on the switch, as it is on the MB01 and MB05 backplanes.

The single +5 V supply powers a clock oscillator, which drives power transformers for the input and output circuits. The input circuit is, of course, fully floating. In addition, the output section acts as a third floating port, eliminating many problems that might be created by ground loops and supply noise. However, the common-mode range of the output circuit is limited: output common must be kept within ± 3 V of power common.

Note: A current path to insure that the voltage from power common to output common remains within ± 3 V must exist for proper operation of the demodulator and output switch.

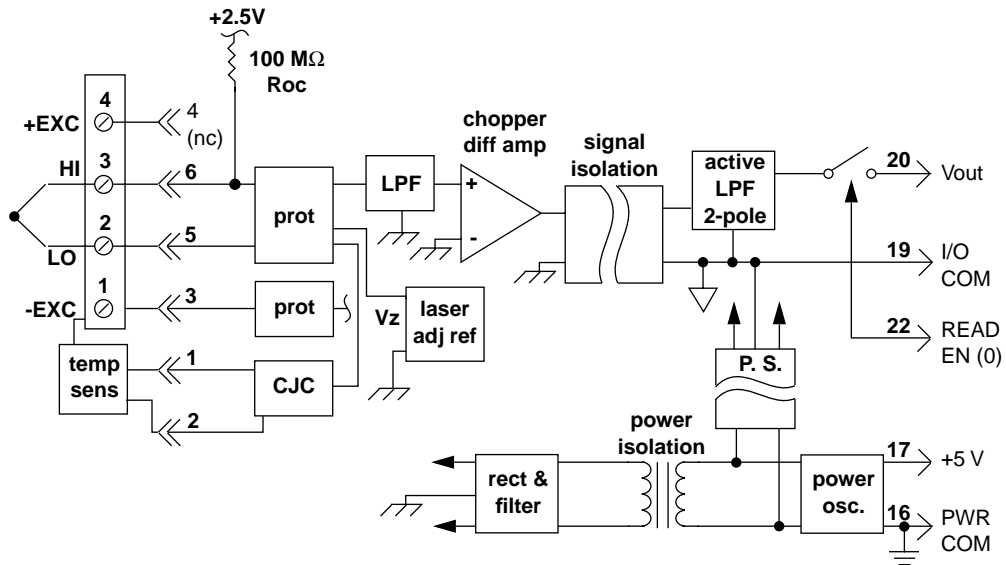

Figure 3-5. MB37 Functional Block Diagram

Table 3-9 lists the specifications for the MB37 module. Note that specifications are typical at 25°C and +5 V and are subject to change without notice. Table 3-10 lists the ordering information for the MB37 module.

Table 3-9. MB37 Specifications

Specification	MB37
Input Span Limits	± 5 mV to ± 0.5 V
Output Range	0 to +5 V
Accuracy ^{1,2}	$\pm 0.05\%$ span ± 10 μ V RTI $\pm 0.05\%$ (V_z) + CJC Sensor, if applicable
Nonlinearity	$\pm 0.02\%$ span
Stability vs. Ambient Temperature Input Offset Output Offset Gain	1 μ V/ $^{\circ}$ C ± 20 μ V/ $^{\circ}$ C ± 25 ppm of reading/ $^{\circ}$ C
Input Bias Current	-25 nA
Input Resistance Normal Power Off Overload	5 M Ω 40 k Ω 40 k Ω
Noise Input, 0.1-10 Hz Output, 100 kHz	0.2 μ V _{rms} RTI 200 μ V _{rms} RTO
Bandwidth, -3 dB	4 Hz
Rise Time, 10% to 90% Span	0.2 s
CMV, Input to Output Continuous Transient	1500 V _{rms} max meets IEEE-STD 472 (SWC)
CMR (50 or 60 Hz) 1 k Ω in Either or Both Input Leads	160 dB (all ranges)
NMR (50 or 60 Hz)	60 dB
Input Protection Continuous	240 V _{rms} max continuous
Output Resistance ³	50 Ω
Voltage Output Protection	Continuous Short to Ground
Output Selection Time	20 μ s

Table 3-9. MB37 Specifications (cont.)

Specification	MB37
Output Selection Input Max Logic "0" Min Logic "1" Max Logic "1" Input Current "0"	+1 V +2.5 V +36 V 0.4 mA
Open Input Response	upscale
Open Input Detection Time	10 s
Cold Junction Compensation Initial Accuracy ⁴ Over +5°C to +45°C	±0.25°C ±0.5°C (±0.0125°C/°C)
Power Supply Voltage	+5 V ±5%
Power Supply Sensitivity	±2 µV/Vs% (RTI)
Power Consumption	150 mW (30 mA)
Size	2.25" x 2.25" x 0.60" (52 mm x 52 mm x 15 mm)
Environmental Temperature Range, Rated Performance Temperature Range, Storage Temperature Range, Operating Relative Humidity (MIL 202) RFI Susceptibility	-25°C to +85°C -40°C to +85°C -40°C to +85°C 0 to 95% @ 60°C noncondensing ±0.5% span error @ 400 MHz, 5 W, 3 feet

Notes

- ¹ Includes the combined effects of repeatability, hysteresis, and nonlinearity and assumes very high load resistance.
- ² V_z is the nominal input voltage that results in a 0 V output.
- ³ The output resistance value can be used to determine gain error when the module is driving a resistive load. However, loads heavier than 20 kΩ will degrade nonlinearity and gain temperature coefficient.
- ⁴ When used with CJC-MB CJC sensor, which is provided on each channel of MB Series backplanes and on the STA-1360.

Table 3-10. MB37 Ordering Information

Input Type	Range	Output Range	Model
Type J	-100°C to +760°C (-148°F to +1400°F)	0 to +5 V	MB37-J-01
Type K	-100°C to +1350°C (-148°F to +2462°F)	0 to +5 V	MB37-K-02
Type T	-100°C to +400°C (-148°F to +752°F)	0 to +5 V	MB37-T-03
Type E	0 to +900°C (+32°F to +1652°F)	0 to +5 V	MB37-E-04
Type R	0 to +1750°C (+32°F to +3182°F)	0 to +5 V	MB37-R-05
Type S	0 to +1750°C (+32°F to +3182°F)	0 to +5 V	MB37-S-05
Type B	0 to +1800°C (+32°F to +3272°F)	0 to +5 V	MB37-B-06

MB38 Strain Gauge Input Module

The MB38 wide bandwidth strain gauge input module accepts signals from full-bridge and half-bridge 300 Ω to 10 k Ω transducers. The MB38 provides +10 V excitation and produces an output of -5 V to +5 V. This module features a bandwidth of 10 kHz.

Figure 3-6 on page 3-26 is a functional block diagram of the MB38. A protection circuit assures safe operation even if a 240 V_{rms} power line is connected to the input screw terminals. The excitation section provides +10 V. Since the excitation lines are not sensed at the strain gauge, care should be taken to minimize any IR loss in these wires. This can be accomplished by the use of heavy gauge wires or the shortest length of wire possible. A one-pole anti-aliasing filter is located at the module's input, while a three-pole low-pass filter in the output stage sets the bandwidth and yields optimum noise performance. A low-drift amplifier provides the module's gain.

Signal isolation is provided by transformer coupling using a proprietary modulation technique for linear, stable performance. A demodulator on the output side of the signal transformer recovers the original signal, which is then filtered and buffered to provide a clean, low-impedance output. A series output switch is included to eliminate the need for external multiplexing in many applications. This switch is controlled by

an active-low enable input. In cases where the output switch is not used, the enable input should be grounded to power common to turn on the switch, as it is on the MB01 and MB05 backplanes.

The single +5 V supply powers a clock oscillator, which drives power transformers for the input and output circuits. The input circuit is fully floating. In addition, the output section acts as a third floating port, eliminating many problems that might be created by ground loops and supply noise. However, the common-mode range of the output circuit is limited: output common must be kept within ± 3 V of power common.

The MB38 can be used with half-bridge transducers since the module contains bridge completion circuitry. There is no provision for use with quarter or three-quarter-bridge strain gauges. However, you may complete the bridge to the half or full-bridge level external to the module and use the MB38 module.

Note: A current path to insure that the voltage from power common to output common remains within ± 3 V must exist for proper operation of the demodulator and output switch.

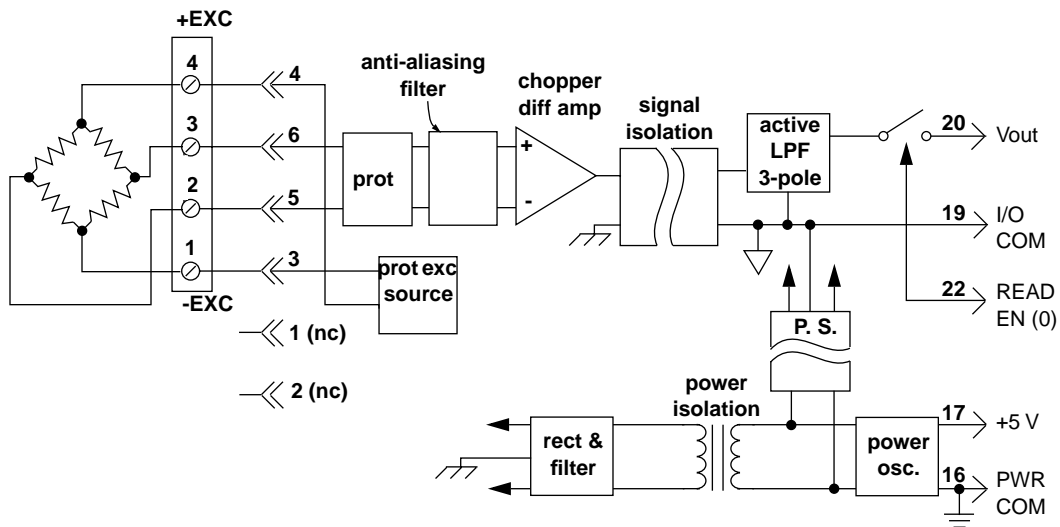

Figure 3-6. MB38 Functional Block Diagram

Table 3-11 lists the specifications for the MB38 module. Note that specifications are typical at 25°C and +5 V and are subject to change without notice.

Table 3-11. MB38 Specifications

Specification	Full Bridge	Half Bridge
Models	MB38-02, MB38-05, MB38-07	MB38-04
Input Span Limits	±30 mV @ 3 mV/V Sensitivity ±20 mV @ 2 mV/V Sensitivity ±100 mV @ 10 mV/V Sensitivity	±30 mV @ 3 mV/V Sensitivity
Output Range	-5 V to +5 V	-5 V to +5 V
Accuracy ¹	±0.08% span ±10 µV RTI	±0.08% span ± 1 mV RTI
Nonlinearity	±0.02% span	±0.02% span
Excitation Output ²	+10 V ± 3 mV	+10 V ± 3 mV
Excitation Load Regulation	±5 ppm/mA	±5 ppm/mA
Half Bridge Voltage Level	N/A	(Excitation Voltage/2) ±1 mV
Stability vs. Ambient Temp. Input Offset Output Offset Gain Excitation Voltage Half Bridge	1 µV/°C ±40 µV/°C ±25 ppm of reading/°C ±15 ppm/°C N/A	1 µV/°C ±40 µV/°C ±25 ppm of reading/°C ±15 ppm/°C ±15 ppm/°C
Input Bias Current	±3 nA	±3 nA
Input Resistance Normal Power Off Overload	20 MΩ minimum 40 kΩ minimum 40 kΩ minimum	20 MΩ minimum 40 kΩ minimum 40 kΩ minimum
Noise Input, bandwidth = 10 Hz Input, bandwidth = 10 kHz Output, bandwidth = 100 kHz	0.4 µV _{rms} RTI ±70 nV/√Hz RTI 10 mV p-p RTO	±2 µV _{rms} RTI ±250 nV/√Hz RTI 10 mV p-p RTO
Bandwidth, -3 dB	10 kHz	10 kHz
Rise Time, 10% to 90% Span	40 µs	40 µs
Settling Time (to 0.1%)	250 µs	7 ms

Table 3-11. MB38 Specifications (cont.)

Specification	Full Bridge	Half Bridge
CMV, Input to Output Continuous Transient	1500 V _{rms} max meets IEEE-STD 472 (SWC)	1500 V _{rms} max meets IEEE-STD 472 (SWC)
CMR (50 or 60 Hz) 1 kΩ in either/both input leads	100 dB	100 dB
Input Protection Continuous	240 V _{rms} max continuous	240 V _{rms} max continuous
Output Resistance	50 Ω	50 Ω
Voltage Output Protection	Continuous Short to Ground	Continuous Short to Ground
Output Selection Time	20 μs	20 μs
Output Selection Input Max Logic "0" Min Logic "1" Max Logic "1" Input Current "0"	+1 V +2.5 V +36 V 0.4 mA	+1 V +2.5 V +36 V 0.4 mA
Power Supply Voltage	+5 V ±5%	+5 V ±5%
Power Supply Sensitivity	25 ppm reading/% ± 2.5 μV RTI/%	25 ppm reading/% ± 2.5 μV RTI/%
Power Consumption	1 W full load, 0.6 W no load	1 W full load, 0.6 W no load
Size	2.25" x 2.25" x 0.60" (52 mm x 52 mm x 15 mm)	2.25" x 2.25" x 0.60" (52 mm x 52 mm x 15 mm)
Environmental Temp. Range, Rated Performance Temp. Range, Storage Temp. Range, Operating Relative Humidity (MIL 202) RFI Susceptibility	-25°C to +85°C -40°C to +85°C -40°C to +85°C 0 to 95% @ 60°C noncondensing ±0.5% span error @ 400 MHz, 5W, 3 feet	-25°C to +85°C -40°C to +85°C -40°C to +85°C 0 to 95% @ 60°C noncondensing ±0.5% span error @ 400 MHz, 5W, 3 feet

Notes

¹ Includes combined effects of gain, offset/excitation errors, repeatability, hysteresis, and nonlinearity.

² At full load (300 Ω).

Table 3-12 lists the ordering information for the MB38 module.

Table 3-12. MB38 Ordering Information

Input Bridge	Range and Excitation	Output Range	Model
Full Bridge	10.0 V excitation, @ 3 mV/V Sensitivity, 300 Ω to 10 k Ω	-5 V to +5 V	MB38-02
Half Bridge	10.0 V excitation, @ 3 mV/V Sensitivity, 300 Ω to 10 k Ω	-5 V to +5 V	MB38-04
Full Bridge	10.0 V excitation, @ 2 mV/V Sensitivity, 300 Ω to 10 k Ω	-5 V to +5 V	MB38-05
Full Bridge	10.0 V excitation, @ 10 mV/V Sensitivity, 300 Ω to 10 k Ω	-5 V to +5 V	MB38-07

MB39 Current Output Module

The MB39 current output module accepts a high level analog signal at its input and provides a galvanically-isolated 4-20 mA or 0-20 mA process current signal at its output. The module features high accuracy of $\pm 0.05\%$, $\pm 0.02\%$ nonlinearity and 1500 V_{rms} common mode voltage isolation protection.

Figure 3-7 on page 3-31 is a functional block diagram of the MB39 current output module. The voltage input, usually from a digital-to-analog converter, is buffered and a quarter scale offset is added if a 4-20 mA output is specified.

The signal is latched in a track-and-hold circuit. This track-and-hold allows one DAC to serve numerous output channels. The output droop rate is 80 $\mu\text{A/s}$, which corresponds to a refresh interval of 25 ms for 0.01% FS droop. The track-and-hold is controlled by an active-low enable input. On power-up, the output of the MB39 remains at 0 mA for approximately 100 ms, allowing the user to initialize the track-and-hold.

In conventional applications where one DAC is used per channel and the track-and-hold is not used, the enable input should be grounded to power common, as it is on the MB01 and MB05 backplanes. This keeps the module in tracking mode.

The signal is sent through an isolation barrier to the current output (V-to-I converter) stage. Signal isolation is provided by transformer coupling using a proprietary modulation technique for linear, stable performance. A demodulator on the output side of the signal transformer recovers the original signal, which is then filtered and converted to a current output. Output protection allows safe operation even in the event of a 240 V_{rms} power line being connected to the signal terminals.

A single +5 V supply powers a clock oscillator, which drives power transformers for the input circuit and the output's high-compliance, current loop supply. The output current loop is, of course, fully floating. In addition, the input section acts as a third floating port, eliminating many problems that might be created by ground loops and supply noise. However, the common-mode range of the input circuit is limited: input common must be kept within ± 3 V of power common.

Note: A current path to insure that the voltage from power common to output common remains within ± 1 V must exist for proper operation of the demodulator and output switch.

The 0 to 20 mA output of a MB39-04 can be converted to a 0 to 10 V output by dropping a 500 Ω resistor across the output terminals.

This voltage output should be used cautiously. Since it is not a true voltage source, the tolerance of the resistor and load impedances that are not large relative to the conversion resistor will introduce errors. A load impedance > 500 k Ω would contribute $< 0.1\%$ error.

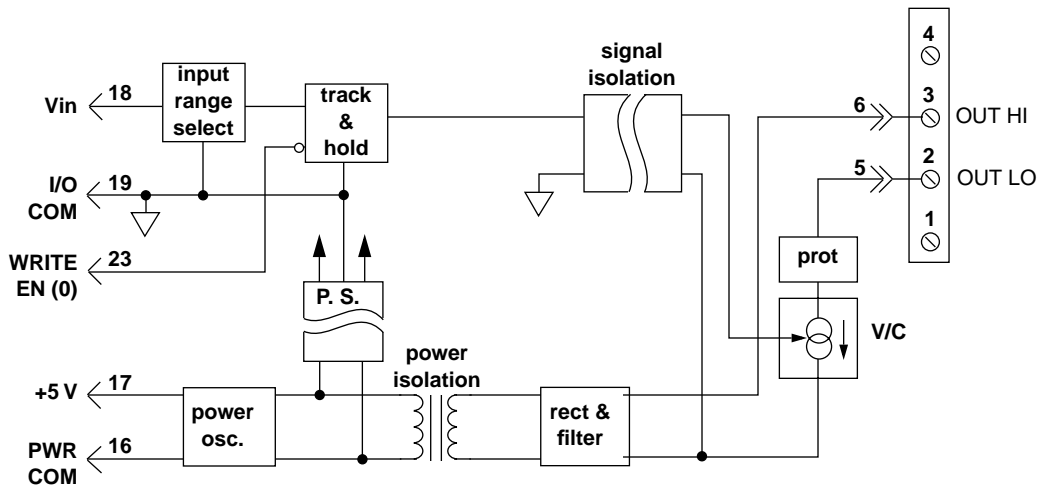

Figure 3-7. MB39 Functional Block Diagram

Table 3-13 lists the specifications for the MB39 module. Note that specifications are typical at 25°C and +5 V and are subject to change without notice. Table 3-14 lists the ordering information for the MB39 module.

Table 3-13. MB39 Specifications

Specification	MB39
Standard Input Ranges	0 to +5 V or -5 V to +5 V
Standard Output Ranges	4-20 mA or 0-20 mA
Load Resistance Range ¹	0 to 650 Ω
Accuracy ²	$\pm 0.05\%$ span
Nonlinearity	$\pm 0.02\%$ span
Stability vs. Ambient Temperature Zero Span	$\pm 0.5 \mu\text{A}/^\circ\text{C}$ $\pm 20 \text{ ppm of reading}/^\circ\text{C}$
Output Ripple, 100 Hz bandwidth	30 μA peak-peak
Common Mode Voltage Output to Input and Power Supply	1500 V_{rms} continuous
Common Mode Rejection	90 dB
Normal Mode Output Protection	240 V_{rms} continuous
Output Transient Protection	Meets IEEE-STD 472 (SWC)
Sample & Hold: Output Droop Rate Acquisition Time	80 $\mu\text{A}/\text{s}$ 50 μs
Overrange Capability	10%
Maximum Output Under Fault	26 mA
Input Resistance	10 $M\Omega$
Bandwidth, -3 dB	400 Hz
Rise Time, 10% to 90% Span	2 ms
Track-and-Hold Enable Max Logic "0" Min Logic "1" Max Logic "1" Input Current "0"	+1 V +2.5 V +36 V 1.5 mA
Power Supply	+5 Vdc $\pm 5\%$
Power Supply Sensitivity	$\pm 0.25 \mu\text{A}/\text{Vs}\%$

Table 3-13. MB39 Specifications (cont.)

Specification	MB39
Power Consumption	0.85 W (170 mA)
Maximum Input Voltage Without Damage	-10 V to +10 V
Size	2.25" x 2.25" x 0.60" (52 mm x 52 mm x 15 mm)
Environmental	
Temperature Range, Rated Performance	-25°C to +85°C
Temperature Range, Operating	-40°C to +85°C
Temperature Range, Storage	-40°C to +85°C
Relative Humidity (MIL 202)	0 to 95% @ 60°C noncondensing
RFI Susceptibility	±0.5% span error @ 400 MHz, 5W, 3 feet

Notes

¹ With a minimum power supply voltage of 4.95 V, R_L can be up to 750 Ω .

² Includes the combined effects of repeatability, hysteresis, and nonlinearity.

Table 3-14. MB39 Ordering Information

Input Range	Output Range	Model
0 to +5 V	4-20 mA	MB39-01
-5 V to +5 V	4-20 mA	MB39-02
0 to +5 V	0-20 mA	MB39-03
-5 V to +5 V	0-20 mA	MB39-04

MB40 and MB41 Wide Bandwidth Millivolt/Volt Input Modules

The MB40 wide bandwidth millivolt input module accepts ± 5 mV to ± 100 mV input signals and provides either a -5 V to $+5$ V or 0 to $+5$ V output. The MB41 wide bandwidth voltage input module accepts ± 1 V to ± 40 V input signals and provides either a -5 V to $+5$ V or 0 to $+5$ V output. Both modules feature a 10 kHz bandwidth.

Figure 3-8 on page 3-35 is a functional block diagram of the MB40 and MB41. A protection circuit assures safe operation even if a 240 V_{rms} power line is connected to the input, and, in the MB41, the signal is attenuated by a factor of 20 at this point. A one-pole anti-aliasing filter is located at the module's input, while a three-pole low-pass filter in the output stage sets the bandwidth and yields optimum noise performance. A low-drift input amplifier provides all of the module's gain. This amplifier operates on the input signal after subtraction of a stable, laser-trimmed voltage, which sets the zero-scale input value. Therefore, it is possible to suppress a zero-scale input that is many times the total span to provide precise expanded scale measurements.

Signal isolation is provided by transformer coupling using a proprietary modulation technique for linear, stable performance. A demodulator on the output side of the signal transformer recovers the original signal, which is then filtered and buffered to provide a clean, low-impedance output. A series output switch is included to eliminate the need for external multiplexing in many applications. This switch has a low output resistance and is controlled by an active-low enable input. In cases where the output switch is not used, the enable input should be grounded to power common to turn on the switch, as it is on the MB01 and MB05 backplanes.

A single $+5$ V supply powers a clock oscillator that drives power transformers for the input and output circuits. The input circuit is, of course, fully floating. In addition, the output section acts as a third floating port, eliminating many problems that might be created by ground loops and supply noise. However, the common-mode range of the output circuit is limited: output common must be kept within ± 3 V of power common.

Note: A current path to insure that the voltage from power common to output common remains within ± 3 V must exist for proper operation of the demodulator and output switch.

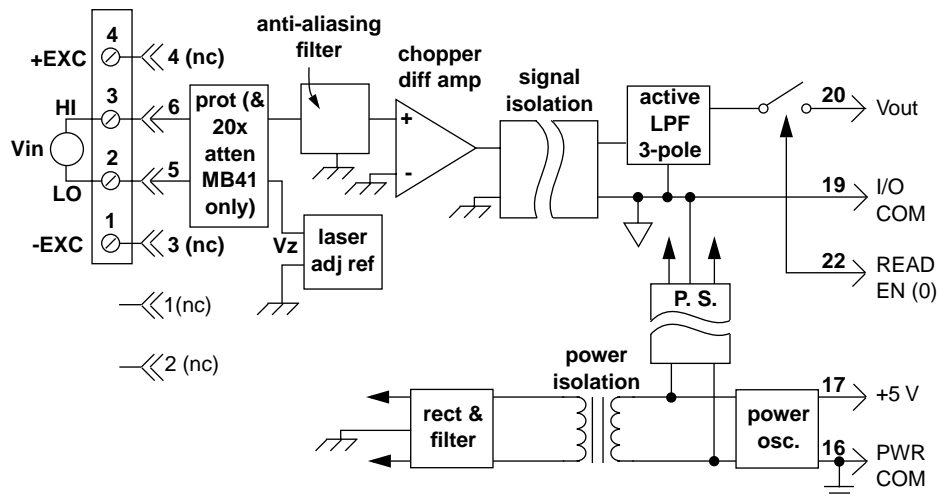

Figure 3-8. MB40 and MB41 Functional Block Diagram

Table 3-15 lists the specifications for the MB40 and MB41 modules. Note that specifications are typical at 25°C and +5 V and are subject to change without notice. Table 3-16 lists the ordering information for the MB40 and MB41 modules.

Table 3-15. MB40 and MB41 Specifications

Specification	MB40	MB41
Input Span Limits	±5 mV to ±100 mV	±1 V to ±40 V
Output Ranges	-5 V to +5 V or 0 to +5 V	-5 V to +5 V or 0 to +5 V
Accuracy ^{1,2}	±0.05% span ±10 µV RTI ±0.05% (V _Z)	±0.05% span ±0.05% (V _Z)
Nonlinearity	±0.02% span	±0.02% span
Stability vs. Ambient Temperature Input Offset Output Offset Gain	±1 µV/°C ±40 µV/°C ±25 ppm of reading/°C	±20 µV/°C ±40 µV/°C ±50 ppm of reading/°C
Input Bias Current	±3 nA	±0.2 nA
Input Resistance Normal Power Off Overload	200 MΩ 40 kΩ 40 kΩ	650 kΩ 650 kΩ 650 kΩ
Noise Input, 0.1-10 Hz Output V _i =±FS V _i =0	0.4 µV _{rms} RTI 20 mV, peak-peak 10 mV, peak-peak	2 µV _{rms} RTI 20 mV, peak-peak 10 mV, peak-peak
Bandwidth, -3 dB	10 kHz	10 kHz
Rise Time, 10% - 90% span	35 µs	35 µs
CMV, Input to Output Continuous Transient	1500 V _{rms} meets IEEE-STD 472 (SWC)	1500 V _{rms} meets IEEE-STD 472 (SWC)
CMR (50 or 60 Hz) 1 kΩ source unbalance	100 dB (all ranges)	90 dB
Input Protection Continuous Transient	240 V _{rms} meets IEEE-STD 472 (SWC)	240 V _{rms} meets IEEE-STD 472 (SWC)
Output Resistance ³	50 Ω	50 Ω
Voltage Output Protection	Continuous Short to Ground	Continuous Short to Ground

Table 3-15. MB40 and MB41 Specifications (cont.)

Specification	MB40	MB41
Output Selection Time	20 μ s	20 μ s
Output Selection Input Max Logic "0" Min Logic "1" Max Logic "1" Input Current "0"	+1 V +2.5 V +36 V 0.4 mA	+1 V +2.5 V +36 V 0.4 mA
Power Supply Voltage	+5 V \pm 5%	+5 V \pm 5%
Power Supply Sensitivity	\pm 2 μ V/% (RTI)	\pm 2 μ V/% (RTI)
Power Consumption	150 mW (30 mA)	150 mW (30 mA)
Size	2.25" x 2.25" x 0.60" (52 mm x 52 mm x 15 mm)	2.25" x 2.25" x 0.60" (52 mm x 52 mm x 15 mm)
Environmental Temperature Range, Rated Performance Temperature Range, Operating Temperature Range, Storage Relative Humidity (MIL 202) RFI Susceptibility	-25°C to +85°C -40°C to +85°C -40°C to +85°C 0 to 95% @ 60°C noncondensing \pm 0.5% span error @ 400 MHz, 5 W, 3 feet	-25°C to +85°C -40°C to +85°C -40°C to +85°C 0 to 95% @ 60°C noncondensing \pm 0.5% span error @ 400 MHz, 5 W, 3 feet

Notes

- ¹ Includes the combined effects of repeatability, hysteresis and nonlinearity and assumes very high load resistance.
- ² V_z is the input voltage that results in a 0 V output.
- ³ The output resistance value can be used to determine gain error when the module is driving a resistive load. However, loads heavier than 20 k Ω will degrade nonlinearity and gain temperature coefficient.

Table 3-16. MB40 and MB41 Ordering Information

Input Range	Output Range	Model
-10 mV to +10 mV	-5 V to +5 V	MB40-01
-50 mV to +50 mV	-5 V to +5 V	MB40-02
-100 mV to +100 mV	-5 V to +5 V	MB40-03
-10 mV to +10 mV	0 to +5 V	MB40-04 ¹
-50 mV to +50 mV	0 to +5 V	MB40-05 ¹
-100 mV to +100 mV	0 to +5 V	MB40-06 ¹
-1 V to +1 V	-5 V to +5 V	MB41-01
-5 V to +5 V	-5 V to +5 V	MB41-02
-10 V to +10 V	-5 V to +5 V	MB41-03
-1 V to +1 V	0 to +5 V	MB41-04 ¹
-5 V to +5 V	0 to +5 V	MB41-05 ¹
-10 V to +10 V	0 to +5 V	MB41-06 ¹
-20 V to +20 V	-5 V to +5 V	MB41-07
-20 V to +20 V	0 to +5 V	MB41-08 ¹
-40 V to +40 V	-5 V to +5 V	MB41-09
-40 V to +40 V	0 to +5 V	MB41-10 ¹

Notes

¹ These ranges map bipolar input ranges into unipolar output ranges; 0 maps to +2.5 V.

MB45 Frequency Input Module

The MB45 frequency input module provides a single channel of frequency input that is isolated and converted to a high-level analog voltage output (0 to 5 V). The voltage output is logic-switch controlled, which allows these modules to share a common analog bus without requiring external multiplexers.

Figure 3-9 on page 3-40 is a functional block diagram of the MB45.

The frequency input signal can be a TTL-level signal or a zero-crossing signal. Terminal 3 (+In) on the field-side terminal block is the "common" or ground connection for input signals. A TTL signal is connected from terminal 2 (-In) to terminal 3 (+In), while a zero-crossing signal is connected from terminal 4 (+EXC) to terminal 3 (+In). Input circuitry for each of the signal types has hysteresis built in. An input signal must cross entirely through the hysteresis region to trigger the threshold comparator.

Excitation (5.1 V) is available for use with magnetic pickup or contact-closure type sensors. The excitation is available on terminal 1 (-EXC); the excitation common is terminal 3 (+In).

The MB45 frequency input module contains a completely isolated computer-side circuit that you can float to ± 50 V from PWR COM, pin 16. Complete isolation means that no connection is required between I/O COM and PWR COM for proper operation of the output switch. If desired, you can turn on the output switch continuously by connecting pin 22, the READ EN pin, to I/O COM, pin 19.

The module is powered from +5 VDC, $\pm 5\%$. A special circuit in the module provides protection against accidental connection of power-line voltages up to 240 VAC.

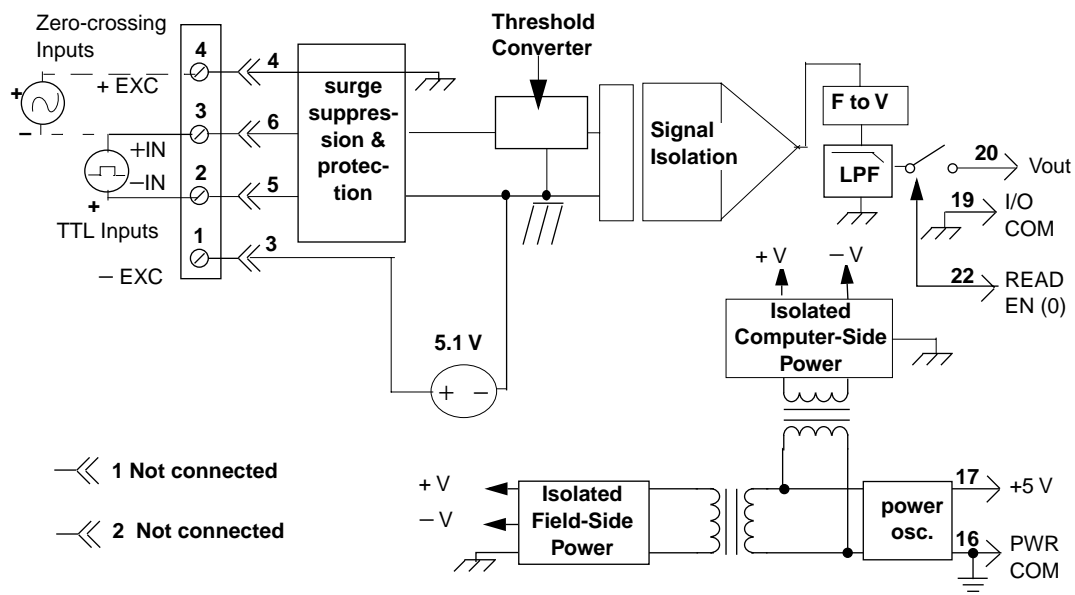

Figure 3-9. MB45 Functional Block Diagram

Table 3-19 lists the specifications for the MB45 module. Note that specifications are typical at 25°C and +5 V and are subject to change without notice. Table 3-20 lists the ordering information for the MB45 module.

Table 3-17. MB45 Specifications

Specification	MB45
Input Range	0 to 100 kHz
Output Range	0 to +5 V
Input Threshold	Zero-crossing
Minimum Pulse Width	4 μ s
Minimum Input	60 mV p-p
Maximum Input	60 V p-p
TTL Input Low	0.8 V max
TTL Input High	2.4 V min
Accuracy ¹	± 0.05 % span
Nonlinearity	± 0.02 % span
Input Resistance	
Normal	100 k Ω
Power Off	100 k Ω
Overload	100 k Ω
Stability	
Offset	± 40 ppm/ $^{\circ}$ C
Gain	± 40 ppm/ $^{\circ}$ C
Input Hysteresis	
Zero-crossing	0.04 V
TTL	1.5 V
Input Protection	
Continuous	240 V _{rms}
Transient	ANSI/IEEE C37.90.1-1989
Response Time	
MB45-01, MB45-02	300 ms
MB45-03	170 ms
MB45-04, MB45-05	90 ms
MB45-06, MB45-07, MB45-08	20 ms
CMV, Input to Output	
Continuous	1500 V _{rms} max
Transient	ANSI/IEEE C37.90.1-1989
CMR (50 or 60 Hz)	120 dB
Excitation Voltage	5.1 V @ 8 mA max

Table 3-17. MB45 Specifications (cont.)

Specification	MB45
Output Noise	<10 mV p-p @ input > 2% span
Output Resistance	50 Ω
Output Protection	Continuous short to ground
Output Selection Time (to ± 1 mV of V_{OUT})	6 μ s at $C_{Load} = 0$ to 2000 pF
Output Enable Control Max Logic "0" Min Logic "1" Max Logic "1" Input Current "0, 1"	+0.8 V +2.4 V +36 V 0.5 μ A
Power Supply Voltage	+5 VDC $\pm 5\%$
Power Supply Sensitivity	$\pm 150 \mu$ V/% RTO ²
Power Supply Current	110 mA
Size	2.28" x 2.26" x 0.60" (58 mm x 57 mm x 15 mm)
Environmental Temperature Range, Rated Performance Temperature Range, Operating Temperature Range, Storage Relative Humidity (MIL 202) RFI Susceptibility	-25°C to +85°C -40°C to +85°C -40°C to +85°C 0 to 95% @ 60°C noncondensing $\pm 0.5\%$ span error @ 400 MHz, 5 W, 3 feet

Notes

¹ Includes nonlinearity, hysteresis, and repeatability.

² Referenced to output.

Table 3-18. MB45 Ordering Information

Input Range	Output Range	Model
0 to 500 Hz	0 to +5 V	MB45-01
0 to 1 kHz	0 to +5 V	MB45-02
0 to 3 kHz	0 to +5 V	MB45-03
0 to 5 kHz	0 to +5 V	MB45-04
0 to 10 kHz	0 to +5 V	MB45-05
0 to 25 kHz	0 to +5 V	MB45-06
0 to 50 kHz	0 to +5 V	MB45-07
0 to 100 kHz	0 to +5 V	MB45-08

MB47 Linearized Thermocouple Input Module

The MB47 thermocouple input module accepts input signals from types J, K, T, E, R, S, and B thermocouples and provides a 0 to +5 V output. The input signal is internally linearized to provide an output that is linear with temperature.

Figure 3-10 on page 3-45 is a functional block diagram for the MB47. Cold junction compensation circuitry corrects for the effects of the parasitic thermocouples formed by thermocouple wire connections to the input screw terminals. The compensator provides an accuracy of $\pm 0.5^{\circ}\text{C}$ over the $+5^{\circ}\text{C}$ to $+45^{\circ}\text{C}$ ambient temperature range. A bias current supplied through resistor R_{oc} gives a predictable upscale response to an open thermocouple. (Downscale open thermocouple detection can be provided by installing a $50\text{ M}\Omega$ resistor across screw terminals 1 and 3. This resistor could be a 0.25 W carbon composition; $\pm 20\%$ tolerance is suitable.)

A protection circuit assures safe operation even if a 240 V_{rms} power line is connected to the input screw terminals. A three-pole filter with a 4 Hz cutoff provides 60 dB of normal-mode rejection and 160 dB of CMR enhancement at 60 Hz. A chopper-stabilized input amplifier provides all of the module's gain and assures low drift. This amplifier operates on the input signal after subtraction of a stable, laser-trimmed voltage, which sets the zero-scale input value. It is, therefore, possible to suppress a zero-scale input that is many times the total span to provide precise expanded scale measurements.

Signal isolation is provided by transformer coupling using a proprietary modulation technique for linear, stable performance. A demodulator on the output side of the signal transformer recovers the original signal, which is then filtered and buffered to provide a clean, low-impedance output. A series output switch is included to eliminate the need for external multiplexing in many applications. This switch has a low output resistance and is controlled by an active-low enable input. In cases where the output switch is not used, the enable input should be grounded to power common to turn on the switch, as it is on the MB01 and MB05 backplanes.

The single +5 V supply powers a clock oscillator that drives power transformers for the input and output circuits. The input circuit is, of course, fully floating. In addition, the output section acts as a third floating port, eliminating many problems that might be created by ground loops and supply noise. However, the common mode range of the output circuit is limited: output common must be kept within ± 3 V of power common.

Note: A current path to insure that the voltage from power common to output common remains within ± 3 V must exist for proper operation of the demodulator and output switch.

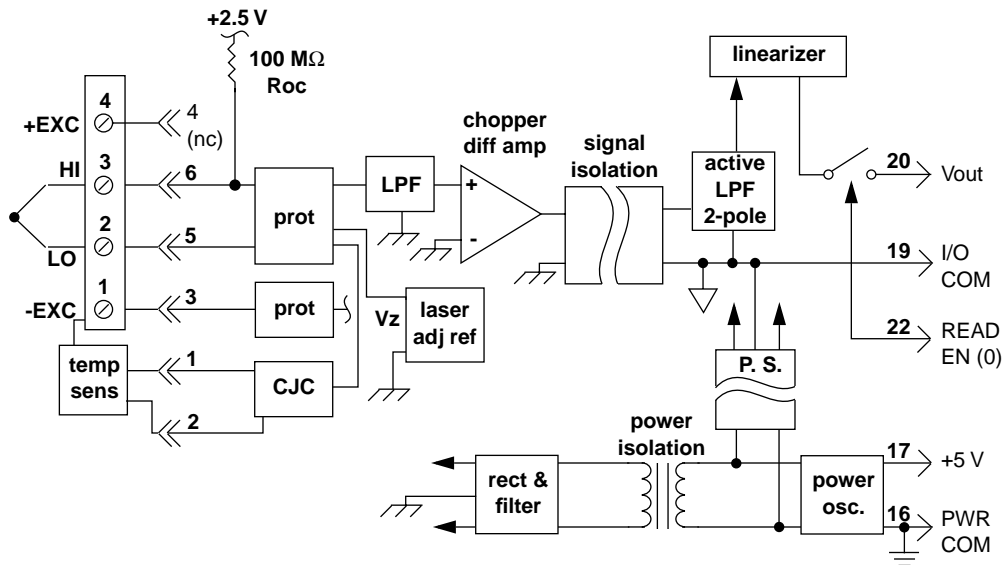

Figure 3-10. MB47 Functional Block Diagram

Table 3-19 lists the specifications for the MB47 module. Note that specifications are typical at 25°C and +5 V and are subject to change without notice. Table 3-20 lists the ordering information for the MB47 module.

Table 3-19. MB47 Specifications

Specification	MB47
Input Span Limits	± 5 mV to ± 0.5 V
Output Range	0 to +5 V
Accuracy ¹	See Ordering Information
Stability vs. Ambient Temperature Input Offset ² Gain	± 1 μ V/ $^{\circ}$ C ± 25 ppm of reading/ $^{\circ}$ C
Input Bias Current	-25 nA
Input Resistance Normal Power Off Overload	5 M Ω 40 k Ω 40 k Ω
Output Noise, 100 kHz	500 μ V _{rms} RTO
Bandwidth, -3 dB	4 Hz
Rise Time, 10% to 90% Span	0.2 s
CMV, Input to Output Continuous Transient	1500 V _{rms} max meets IEEE-STD 472 (SWC)
CMR (50 or 60 Hz) 1 k Ω in Either or Both Input Leads	160 dB (all ranges)
NMR (50 or 60 Hz)	60 dB
Input Protection Continuous	240 V _{rms} max continuous
Output Resistance ³	50 Ω
Voltage Output Protection	Continuous Short to Ground
Output Selection Time	20 μ s
Output Selection Input Max Logic "0" Min Logic "1" Max Logic "1" Input Current ("0")	+1 V +2.5 V +36 V 0.4 mA

Table 3-19. MB47 Specifications (cont.)

Specification	MB47
Open Input Response	upscale
Open Input Detection Time	10 s
Cold Junction Compensation Initial Accuracy ⁴ Over +5°C to +45°C	±0.25°C ±0.5°C (±0.0125°C/°C)
Power Supply Voltage	+5 V ±5%
Power Supply Sensitivity	±2 µV/Vs% (RTI)
Power Consumption	150 mW (30 mA)
Size	2.25" x 2.25" x 0.60" (52 mm x 52 mm x 15 mm)
Environmental Temperature Range, Rated Performance Temperature Range, Operating Temperature Range, Storage Relative Humidity (MIL 202) RFI Susceptibility	-25°C to +85°C -40°C to +85°C -40°C to +85°C 0 to 95% @ 60°C noncondensing ±0.5% span error @ 400 MHz, 5 W, 3 feet

Notes

- ¹ Includes the combined effects of repeatability, hysteresis, and nonlinearity and assumes very high load resistance.
- ² ±1 µV/°C is equivalent to .020°C/°C for Type J thermocouples and .025°C/°C for Type K and T thermocouples.
- ³ The output resistance value can be used to determine gain error when the module is driving a resistive load. However, loads heavier than 20 kΩ will degrade nonlinearity and gain temperature coefficient.
- ⁴ When used with CJC-MB CJC sensor, which is provided on each channel of MB Series backplanes and on the STA-1360.

Table 3-20. MB47 Ordering Information

Input Type	Range	Output Range	Model	Accuracy ¹ (typ)
Type J	0 to +760°C (+32°F to +1400°F)	0 to +5 V	MB47-J-01	±1.1°C
Type J	-100°C to +300°C (-148°F to +572°F)	0 to +5 V	MB47-J-02	±0.5°C
Type J	0 to +500°C (+32°F to +932°F)	0 to +5 V	MB47-J-03	±0.6°C
Type K	0 to +1000°C (+32°F to +1832°F)	0 to +5 V	MB47-K-04	±1.3°C
Type K	0 to +500°C (+32°F to +932°F)	0 to +5 V	MB47-K-05	±0.6°C
Type T	-100°C to +400°C (-148°F to +752°F)	0 to +5 V	MB47-T-06	±1.4°C
Type T	0 to +200°C (+32°F to +392°F)	0 to +5 V	MB47-T-07	±0.5°C
Type E	0 to +1000°C (+32°F to +1832°F)	0 to +5 V	MB47-E-08	±1.7°C
Type R	+500°C to +1750°C (+932°F to +3182°F)	0 to +5 V	MB47-R-09	±2.5°C
Type S	+500°C to +1750°C (+932°F to +3182°F)	0 to +5 V	MB47-S-10	±2.4°C
Type B	+500°C to +1800°C (+932°F to +3272°F)	0 to +5 V	MB47-B-11	±5.1°C

Notes

¹ The CJC sensor accuracy should be added to the module accuracy for a system accuracy, if applicable.

MBAF Series Low-Pass Active Filter Modules

The MBAF Series are differential input 9-pole Butterworth and Bessel low-pass anti-aliasing filters that are pinout and package compatible with industry standard MB Series signal conditioning modules and mechanical equivalents. An ultimate roll-off rate of 54 dB per octave makes these filters ideal for sharply limiting A/D converter bandwidth to eliminate aliasing higher frequency input signals and noise.

A self-contained dc-to-dc converter enables all models to operate from a non-critical +5V ± 10% system bus instead of the usual ±15V dual power supplies. As an added advantage, these modules allow partitioning between system segments and provide a means for minimizing ground loops.

The Butterworth models exhibit the maximally flat pass-band and monotonic roll-off of the classical Butterworth function. The Bessel models exhibit the overshoot-free transient response, linear phase characteristics, and monotonic roll-off of the classical Bessel function.

To serve real-world applications, all MBAF Series filters are configured with a differential input having a common mode rejection ratio of 74 dB (min) at 1 kHz and a common mode input impedance of 20 k Ω (typ).

Both models are available with factory-set standard -3dB corner frequencies of 1 kHz, 2 kHz, 5 kHz, 10 kHz, 20 kHz, and 50 kHz.

Table 3-21. MBAF Series Module Specifications

Specification	MBAF Series
Analog Input Characteristics¹ Voltage Range Differential Gain Common Mode Voltage Range Common Mode Rejection Maximum Safe Voltage Impedance	± 10 V $1 \pm 0.03\%$ ± 20 V 74 dB min at 1 kHz ± 40 V (Power ON or OFF) $20 \text{ k}\Omega \pm 10 \%$
Analog Output Characteristics^{1, 2} Offset Voltage Offset Drift Gain Drift Noise (DC to 50 kHz) Linear Operating Range Resistance Output Load ³	± 3 mV $\pm 100 \mu\text{V}/^\circ\text{C}$ $\pm 30 \text{ ppm}/^\circ\text{C}$ $75 \mu\text{V}_{\text{rms}}$ ± 10 V @ 2 mA 1Ω typ. 10Ω max See note. ³
Filter Characteristics Response Characteristics Frequency Tolerance Corner Frequency (-3 dB) ⁴	9-pole low-pass Butterworth or Bessel $\pm 2 \%$ 1.00 kHz, 2.00 kHz, 5.00 kHz, 10.0 kHz, 20.0 kHz, 50.0 kHz

Table 3-21. MBAF Series Module Specifications (cont.)

Specification	MBAF Series
Power Requirement Power Supply	+5 V \pm 0.5 V 110 mA typ, 125 mA max for 1 kHz to 20 kHz models 120 mA typ, 135 mA max for 50 kHz model
Environmental Operating Temperature Storage Temperature Altitude Relative Humidity	-25 °C to +85 °C -40 °C to +85 °C 10,000 feet 0 % to 95 % @ 60 °C (non-condensing)

Notes

- ¹ Input and output signal voltages are reference to I/O COM.
- ² Output is short-circuit protected to I/O COM. DO NOT CONNECT TO +5 V or POWER COM.
- ³ Output can drive a series 1.5 k Ω resistor and 0.0022 μ F capacitor without slew rate limiting with a \pm 10 V square wave input.

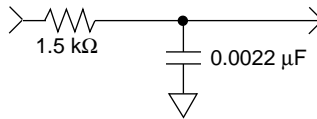

- ⁴ User-specified corner frequencies available from 1.00 kHz to 50.0 kHz.

Figure 3-11 illustrates the frequency response curves for both the Butterworth and Bessel filters.

Butterworth
MBAF-LPBU

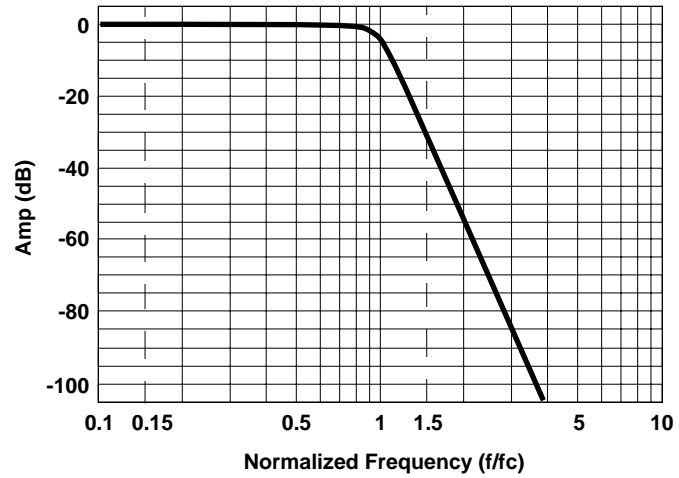

Bessel
MBAF-LPBE

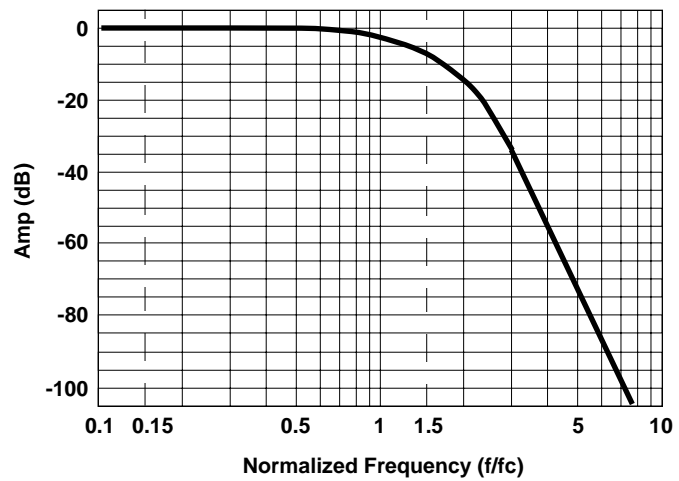
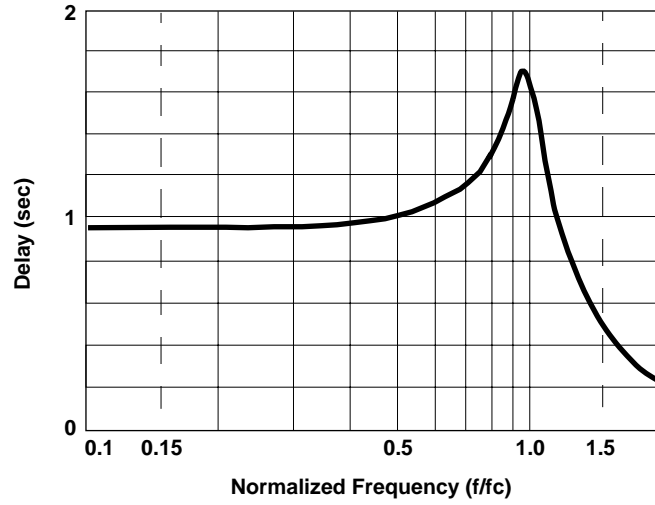

Figure 3-11. 9-Pole Low-Pass Theoretical Frequency Response Curves

Figure 3-12 illustrates the delay curves for both the Butterworth and Bessel filters.

Butterworth
MBAF-LPBU



Bessel
MBAF-LPBE

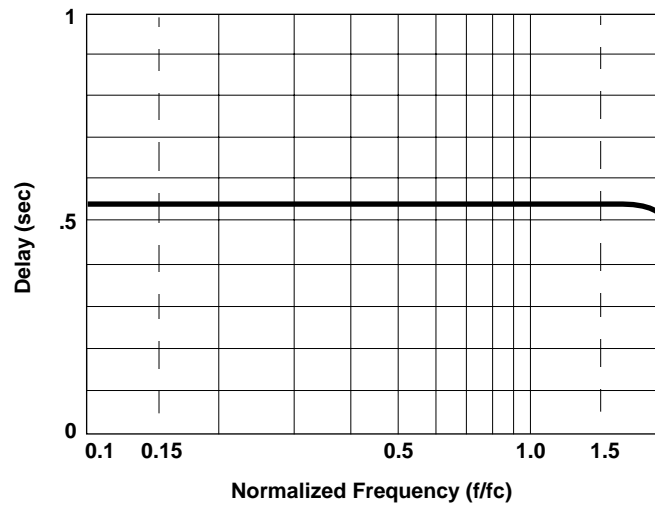
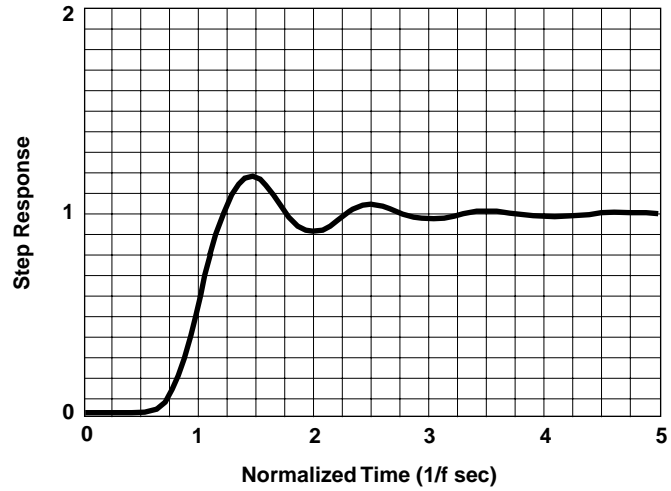

Figure 3-12. 9-Pole Low-Pass Theoretical Delay Curves

Figure 3-13 illustrates the delay curves for both the Butterworth and Bessel filters.

Butterworth
MBAF-LPBU



Bessel
MBAF-LPBE

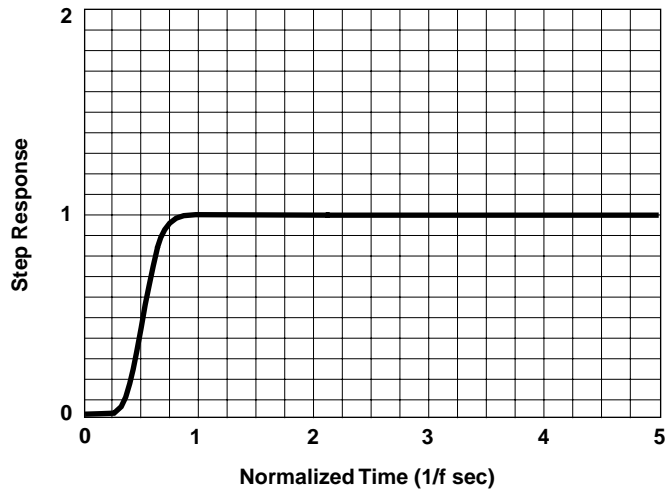

Figure 3-13. 9-Pole Low-Pass Theoretical Step Response Curves

Table 3-22 lists the response data for the Butterworth filter. Table 3-23 lists the response data for the Bessel filter.

Table 3-22. MBAF-LPBU Butterworth (9-Pole) Low-Pass Theoretical Response Data

f/f_c	Amp (dB)	Phase (deg)	Delay
0.00	0.0	0.0	0.916
0.10	0.0	-33.0	0.919
0.20	0.0	-66.3	0.929
0.30	0.0	-100.1	0.947
0.40	0.0	-134.6	0.974
0.50	0.0	-170.3	1.013
0.60	0.0	-207.7	1.071
0.70	0.0	-247.8	1.163
0.80	-0.1	-292.3	1.325
0.90	-0.6	-344.5	1.591
1.00	-3.0	-405.0	1.692
1.20	-14.4	-501.4	0.975
1.50	-31.7	-575.9	0.501
2.00	-54.2	-639.7	0.253
2.50	-71.6	-675.4	0.156
3.00	-85.9	-698.5	0.106
4.00	-108.4	-726.9	0.059
5.00	-125.8	-743.7	0.037
6.00	-140.1	-754.8	0.026
7.00	-152.1	-762.8	0.018
8.00	-162.6	-768.7	0.014
9.00	-171.8	-773.3	0.011
10.0	-180.0	-777.0	0.009

Table 3-23. MBAF-LPBU Bessel (9-Pole) Low-Pass Theoretical Response Data

f/f_c	Amp (dB)	Phase (deg)	Delay
0.00	0.0	0.0	0.540
0.10	0.0	-19.4	0.540
0.20	-0.1	-38.9	0.540
0.30	-0.3	-58.3	0.540
0.40	-0.5	-77.7	0.540
0.50	-0.7	-97.2	0.540
0.60	-1.1	-116.6	0.540
0.70	-1.5	-136.0	0.540
0.80	-1.9	-155.5	0.540
0.90	-2.4	-174.9	0.540
1.00	-3.0	-194.3	0.540
1.20	-4.4	-233.2	0.540
1.50	-7.0	-291.5	0.539
2.00	-13.4	-387.6	0.520
2.50	-22.8	-473.5	0.419
3.00	-34.0	-536.8	0.290
4.00	-54.5	-611.9	0.150
5.00	-71.3	-654.0	0.091
6.00	-85.3	-681.1	0.062
7.00	-97.2	-700.0	0.045
8.00	-107.6	-714.0	0.034
9.00	-116.7	-724.9	0.027
10.0	-124.9	-733.5	0.022

Table 3-24 lists ordering information for MBAF Series modules.

Table 3-24. MBAF Series Model Numbers

Butterworth	Bessel	3 dB Corner Frequency
MBAF-LPBU-1.00K	MBAF-LPBE-1.00K	1.00 kHz
MBAF-LPBU-2.00K	MBAF-LPBE-2.00K	2.00 kHz
MBAF-LPBU-5.00K	MBAF-LPBE-5.00K	5.00 kHz
MBAF-LPBU-10.0K	MBAF-LPBE-10.0K	10.0 kHz
MBAF-LPBU-20.0K	MBAF-LPBE-20.0K	20.0 kHz
MBAF-LPBU-50.0K	MBAF-LPBE-50.0K	50.0 kHz

4

MB Series Backplane Descriptions

This chapter provides detailed descriptions of MB Series backplanes. It includes the following sections:

- MB01, MB02, and MB05 backplanes
- MB03 and MB04 backplanes
- STA-1360 backplane
- STA-MB backplane

MB01, MB02, and MB05 Backplanes

MB01 and MB02 are 16-channel backplanes that you can mount in a 19-inch equipment rack. The MB05 is an 8-channel backplane that you can mount in a 19-inch equipment rack. You can also mount each backplane on a panel using standoffs, which are included.

The MB01, diagrammed in Figure 4-1, provides single-ended, high-level analog input/output pins on the system connector for a total of 16 channels.

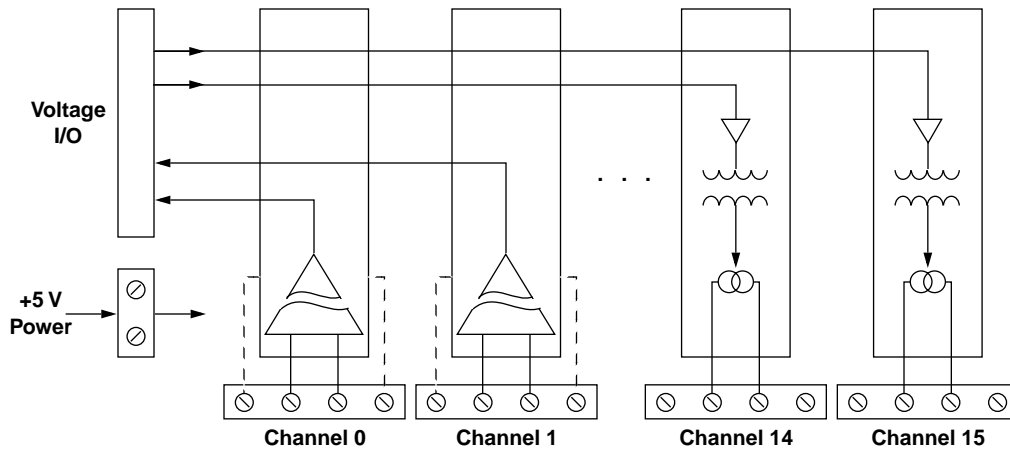

Figure 4-1. MB01 Backplane Diagram

The MB02, diagrammed in Figure 4-2, incorporates input and output buses that take advantage of the internal series output switches in the input modules and the track-and-holds in the output modules. The MB02's internal multiplexing lets you use a single digital-to-analog/analog-to-digital converter to serve numerous output channels. You can use digital outputs from the measurement/control system to address the MB Series modules and designate inputs and outputs. Only one analog input, one analog output, and four digital outputs are required to address up to 64 analog input/output channels.

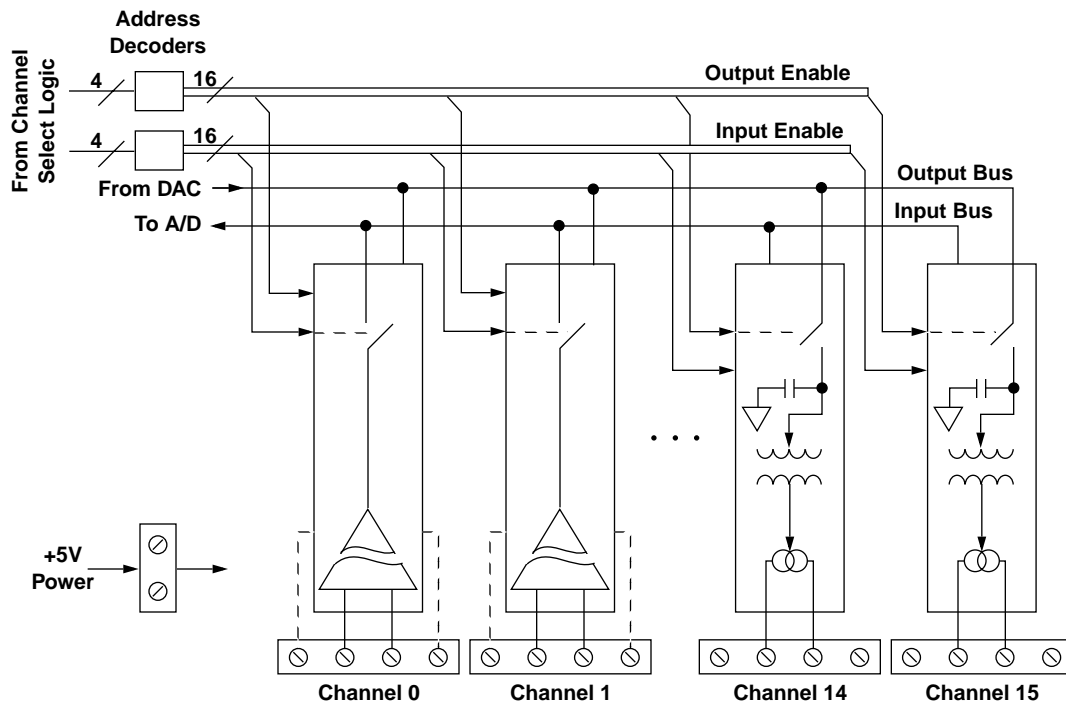

Figure 4-2. MB02 Backplane Diagram

The MB05, diagrammed in Figure 4-3, provides single-ended, high-level analog input/output pins on the system connector for a total of 8 channels.

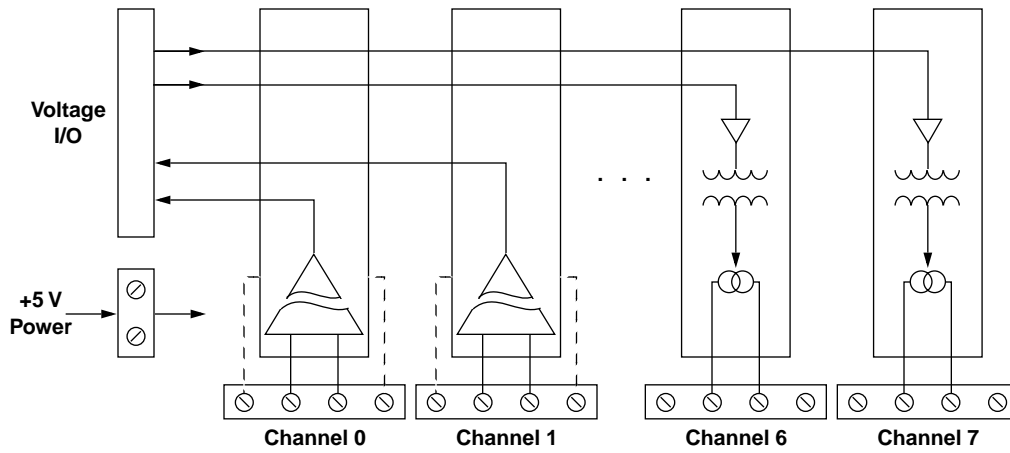

Figure 4-3. MB05 Backplane Diagram

System Connectors

This section describes the system connectors that provide the interface between the MB01, MB05, and MB02 backplanes and the data acquisition system.

MB01 and MB05 System Connectors

Signal connections between the MB01/MB05 backplane and the associated data acquisition system are made at the connectors labeled on the backplane as P1 and P2. These connectors have identical pinouts. The redundant connector is useful if you are using an MB01/MB05 for both analog input and analog output and the associated data acquisition system has separate input and output connectors. Figure 4-4 shows the pinout of P1 and P2.

Note: On-board jumpers J5 to J12 on the MB05 allow you to choose either low (0 to 7) addresses or high addresses (8 to 15) for the eight channels. By connecting two MB05 backplanes with one backplane set for low addresses and the other set for high addresses, you can achieve the functionality of one MB01.

The connector provides a number of grounding pins for interchannel shield conductors in the ribbon cable. In some cases the ground conductors do not provide an accurate signal reference, so the connector provides a SENSE pin.

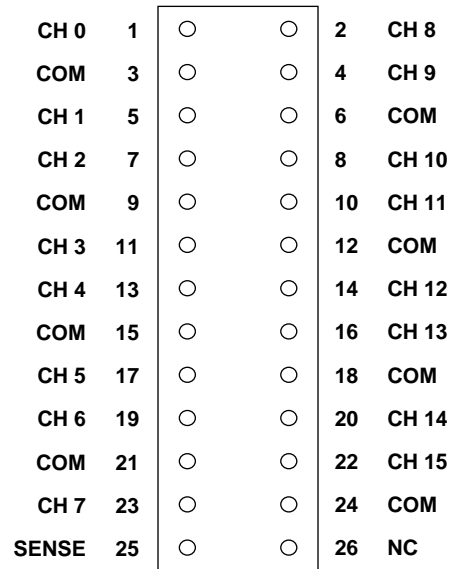

TOP VIEW

Mating connector
AMP PN499485-6
or equivalent

Figure 4-4. MB01/MB05 System Connector Pinout (P1 and P2)

MB02 System Connector

Signal connections between the MB02 backplane and the associated data acquisition system are made at the connector labeled on the backplane as P1. Figure 4-5 shows the pinout of P1.

One signal path is provided for inputs and one for outputs. Input and output modules are independently addressed by two sets of six address pins and an enable pin. In addition, a number of grounded pins provide for shield conductors in the ribbon cable. In some cases the ground conductors do not provide an accurate signal reference, so a SENSE pin is also provided.

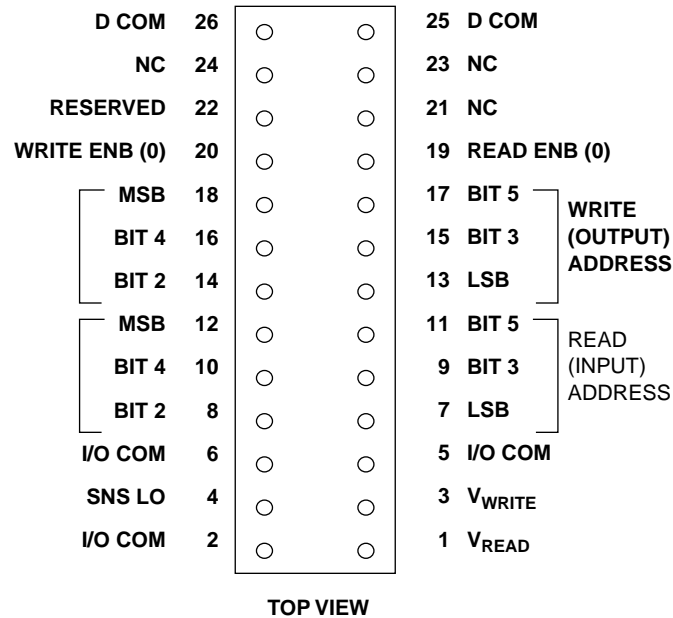

V_{READ} is the analog output of input modules.
V_{WRITE} is the analog input of output modules.

Mating connector AMP PN499485-6 or equivalent

Figure 4-5. MB02 System Connector Pinout (P1)

Grounding

This section describes the jumpers located on the MB01, MB02, and MB05 backplanes to provide optimum ground connections for various circumstances. These jumpers are labelled W1, W2, W3, and W4 on the MB01 and MB02 and J1, J2, J3 and J4 on the MB05. The MB01, MB02, and MB05 backplanes ship with these jumpers installed.

Jumper W1 (J1 on MB05) grounds the shield wires in the ribbon cable (pins 3, 6, 12, 15, 18, 21, and 24 on the MB01 and MB05; pins 2, 5, and 6 on the MB02) at the backplane. This is usually the primary ground connection between the backplane and the data acquisition system. This connection is required if output modules are used on the backplane. It is also required if there is no high-impedance sense input (input LO of a differential or pseudo-differential system) available on the data acquisition system.

On the MB02, jumper W2 connects the sense input, if available, to pin 25 so that the MB02's ground is read. It can be left in place at all times.

Jumper W3 on the MB01 and J3 on MB05 connects the sense input, if available, to pin 25 so that the MB01/MB05 backplane's ground is read. You can leave it in place at all times.

Jumper W4 (J4 on MB05) connects +5 V power common to input/output common (backplane measurement ground). A connection between power common and input/output common is important for the MB Series modules to function properly; however, if this connection is made elsewhere in your system (the best place is usually near the A/D or D/A converters), you should cut W4 (J4 on the MB05) to prevent a ground loop.

The MB Series modules can prevent harm to the connected system even when a very large, fast transient strikes all 16 field I/O lines at the same time. However, proper grounding of the backplane is essential to get full protection, since in such cases, currents on the order of 1 A with rise times on the order of 1 μ s must be diverted to ground. Both the resistance and the inductance of the ground path are critical. In applications where hazards of this magnitude exist, connect the large (#10-32) ground stud(s) (MB01/MB05: two studs at either end; MB02: one stud at one end) to system ground using the shortest practical length of large-diameter wire.

The surge withstand capability can be tested with not less than 50 2.5 kV bursts per second. A test duration of 2 seconds is widely accepted. A rise time of 20 kV/ μ s is specified, and each module could see a surge current on the order of 1 A.

When a safety ground is used, the connection of backplane measurement ground to system measurement ground through the shield wires in the ribbon cable can result in a ground loop. If the application involves only input modules and a sense input is used on the measurement system, cut W1 (J1 on the MB05) to prevent a ground loop.

Note: W1 (J1 on the MB05) is required if you are using output modules or there is no high impedance sense input on the measurement system. In these cases, defend against ground loop errors by minimizing the distance between the backplane and the associated system by routing any large currents carefully so as to minimize ground differences.

Power

All MB Series backplanes require external +5 V power. Chapter 2 describes the power connection.

Since reversing the polarity of the connected +5 V power source can destroy installed modules, the MB01, MB02, and MB05 provide polarity reversal protection in the form of a shunt diode. Reversing the supply blows a series fuse. If the fuse is blown, replace it with the proper type (Littelfuse[®] type 252 004).

Field Terminations

All field terminations of signal wires are made at screw terminal blocks as discussed in Chapter 2. Refer also to Chapter 2 for diagrams of input and output screw terminal connections for the specific modules.

Interchannel Bridge Jumpers (MB01 and MB05 Only)

The MB01 and MB05 backplanes allow you to direct the voltage output of any input module to an adjacent output module by placing a jumper between the pins of the two modules (input to channel n , output from channel $n+1$). You can use this feature to provide an isolated current output from an isolated input module, providing two levels of 1500 V_{rms} isolation.

Address Selection Jumpers (MB02 Only)

The MB02 backplane can hold 16 modules in any combination of inputs or outputs. Address decoders on the backplane determine which module is read (inputs) or driven (outputs). To permit system expansion, you can daisy-chain up to four backplanes for a total of 64 channels. Jumpers on each backplane (labeled SH1-5 and SH6-10) determine the block of 16 addresses assigned to each backplane. Input (read) and output (write) addressing are completely independent; in all cases, jumpers 1-5 control inputs and jumpers 6-10 control outputs. Independent addressing might be used, for example, to update output modules without interrupting the monitoring of input modules.

Backplanes are factory configured with jumpers at positions 1 and 6. Figure 4-6 shows the address jumpers in the factory configured positions. This sets up the backplane as a stand-alone 16-channel system. In this case, the two highest order address bits in the read and write addresses are ignored. Moving the jumpers to any other position in the two blocks enables decoding of the full six address bits; the exact position of the jumper determines address position for the backplane as shown in Table 4-1.

To use multiple backplanes in this manner, connect the corresponding I/O connector pins of each backplane in parallel.

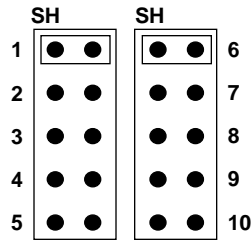

Figure 4-6. Address Selection Pins Showing Default Jumpers

Table 4-1. MB02 Address Selection Jumpers

Input Jumper	Output Jumper	Address Range
2	7	48-63
3	8	32-47
4	9	16-31
5	10	0-15

Mounting

This section provides mounting information for the MB01, MB02, and MB05 backplanes.

Dimensions

The MB01 and MB02 backplanes have seven standoffs; the MB05 has six standoffs. Each backplane ships with 3-mm screws for mounting purposes. Figure 4-7 is a diagram of the mounting dimensions for the MB01 and MB02 backplanes. Figure 4-8 is a diagram of the mounting dimensions for the MB05 backplane.

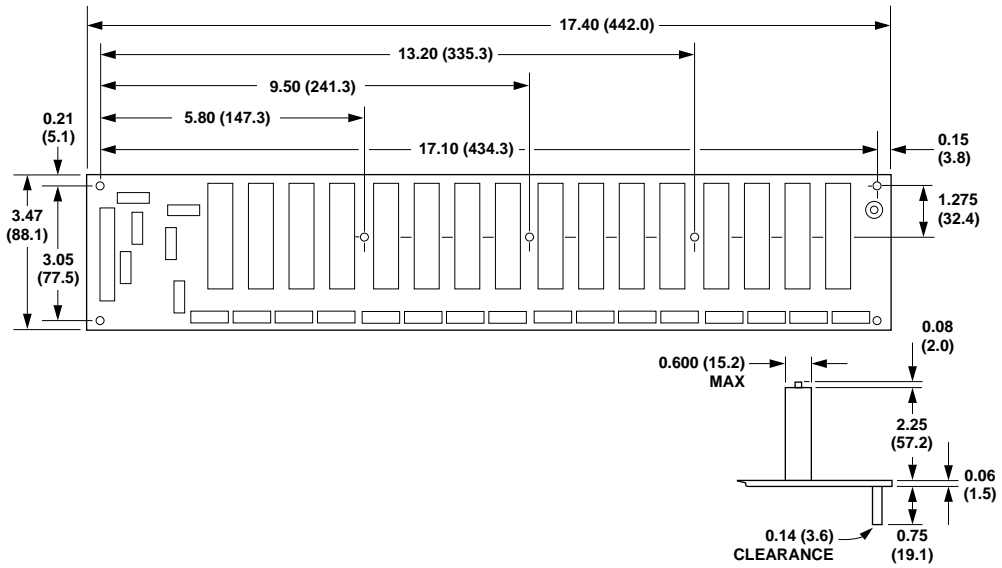

Figure 4-7. MB01 and MB02 Backplane Mounting Dimensions

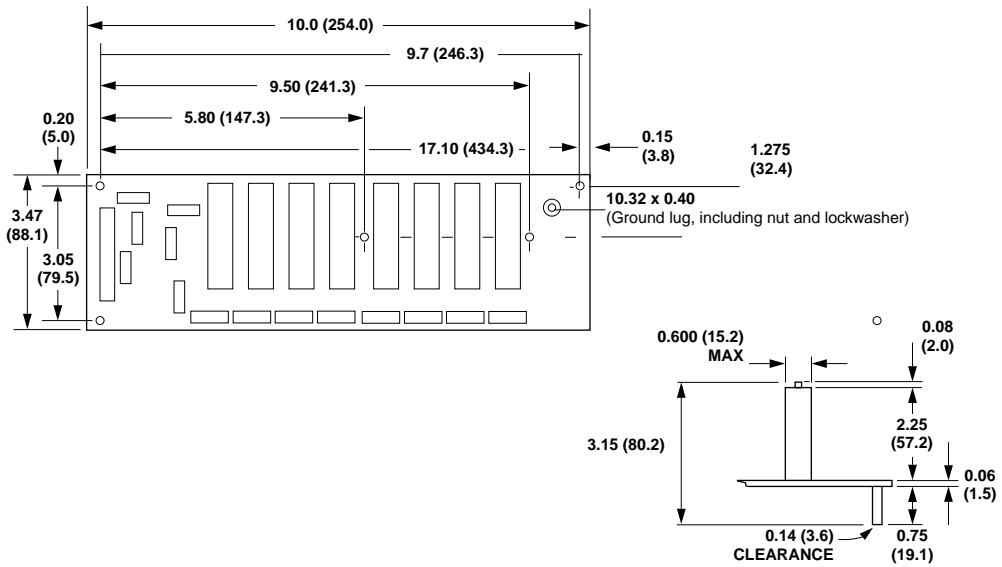

Figure 4-8. MB05 Backplane Mounting Dimensions

RMT-MBBP Rack Enclosure

The RMT-MBBP is a single piece metal chassis for mounting a MB01, MB02, or MB05 backplane in a 19-inch rack. It has seven 3-mm threaded inserts for mounting a MB01, MB02, or MB05, six additional threaded inserts to allow mounting of an adaptor board on the back of the rack mount kit, and holes that allow a PWR-51A or PWR-55A power supply to be mounted on the back of the rack. Screws are also included. The backplane fits readily in the chassis by sliding it in from the side under the end flanges. The RMT-MBBP weighs 1.70 lb (775 g). Figure 4-9 is a diagram of the RMT-MBBP rack-mount kit, and Figure 4-10 is a rack mount assembly drawing.

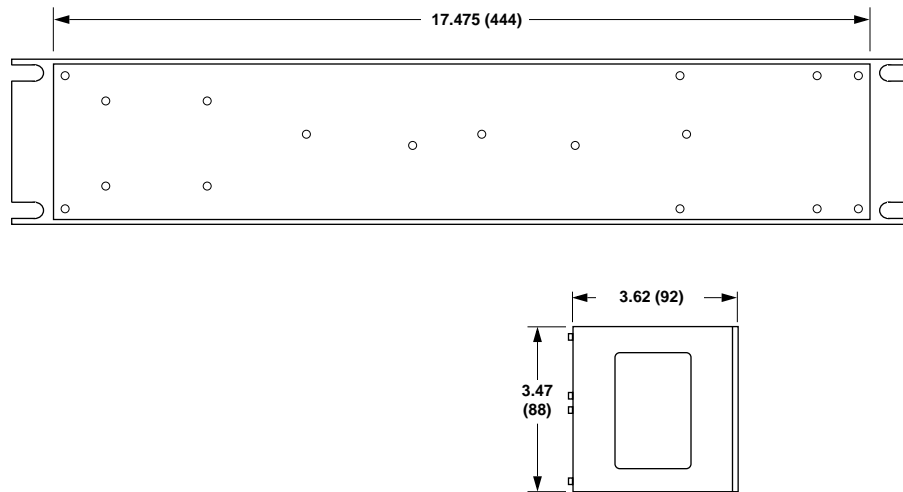

Figure 4-9. RMT-MBBP Rack Mount Diagram

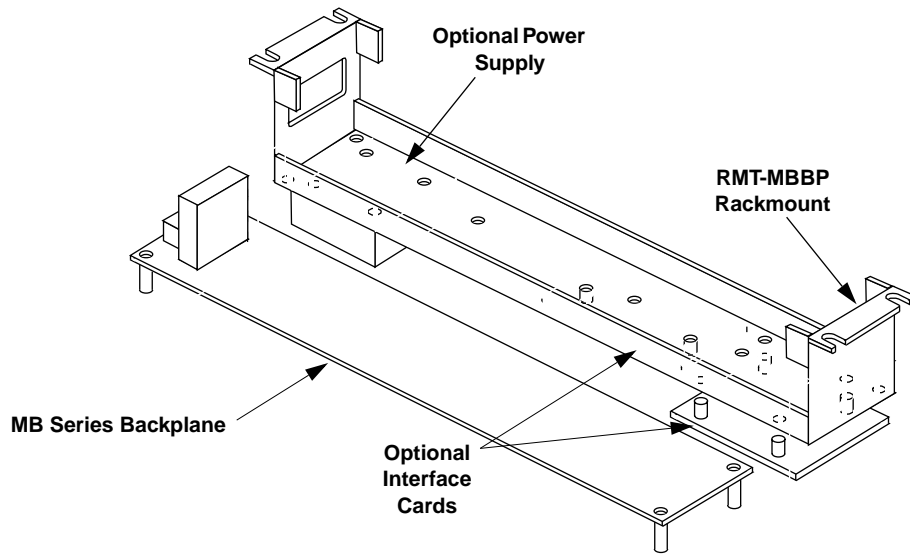

Figure 4-10. RMT-MBBP Rack Mount Assembly Drawing

Specifications

Table 4-2 lists the specifications for the MB01, MB02, and MB05 backplanes. These are subject to change without notice.

Table 4-2. MB01, MB02, and MB05 Backplane Specifications

Specification	MB01	MB02	MB05
Channels	16	16	8
Physical Size (with modules)	3.5" x 17.4" x 3.2" (88.9 mm x 442 mm x 81.3 mm)	3.5" x 17.4" x 3.2" (88.9 mm x 442 mm x 81.3 mm)	3.5" x 17.4" x 3.2" (88.9 mm x 442 mm x 81.3 mm)
Weight	11.25 oz. (305 g)	11.25 oz. (305 g)	6.5 oz. (175 g)
Address Selection Inputs			
Max Logic "0"	N/A	0.8 V	N/A
Min Logic "1"	N/A	2.0 V	N/A
Max Logic "1"	N/A	7.0 V	N/A
Power Supply	+5 VDC \pm 5%	+5 VDC \pm 5	+5 VDC \pm 5
Power Consumption	N/A	0.16 W (32 mA) typ	N/A

MB03 and MB04 Backplanes

The MB03 backplane holds one MB Series module and the MB04 holds two modules. You can cluster these backplanes for larger groups of modules. Figure 4-11 and Figure 4-12 show the wiring diagrams for the MB03 and MB04.

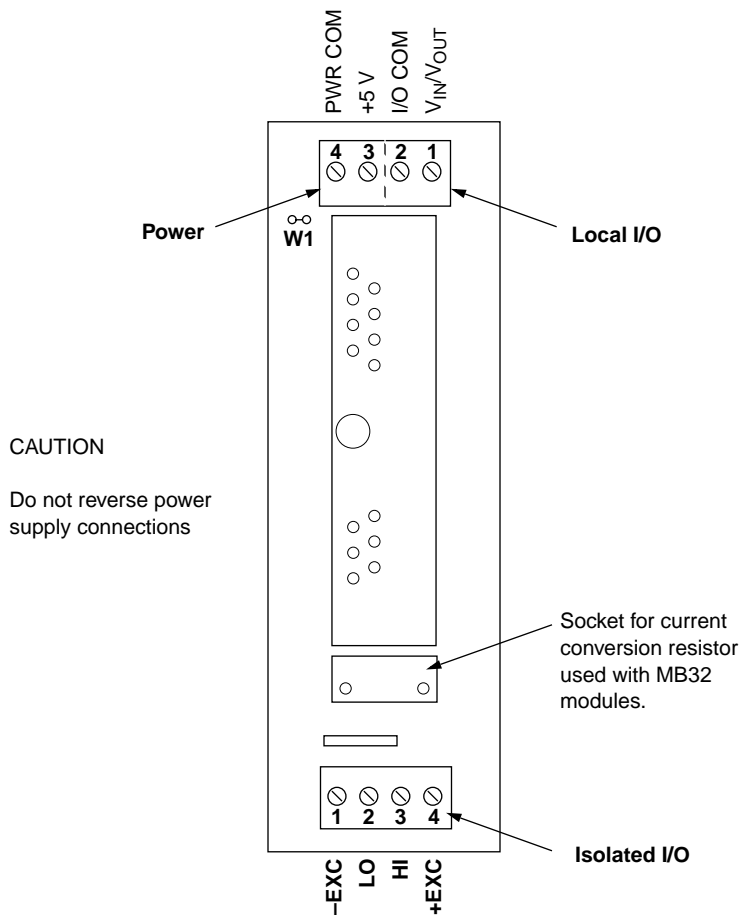

Figure 4-11. MB03 Wiring Diagram

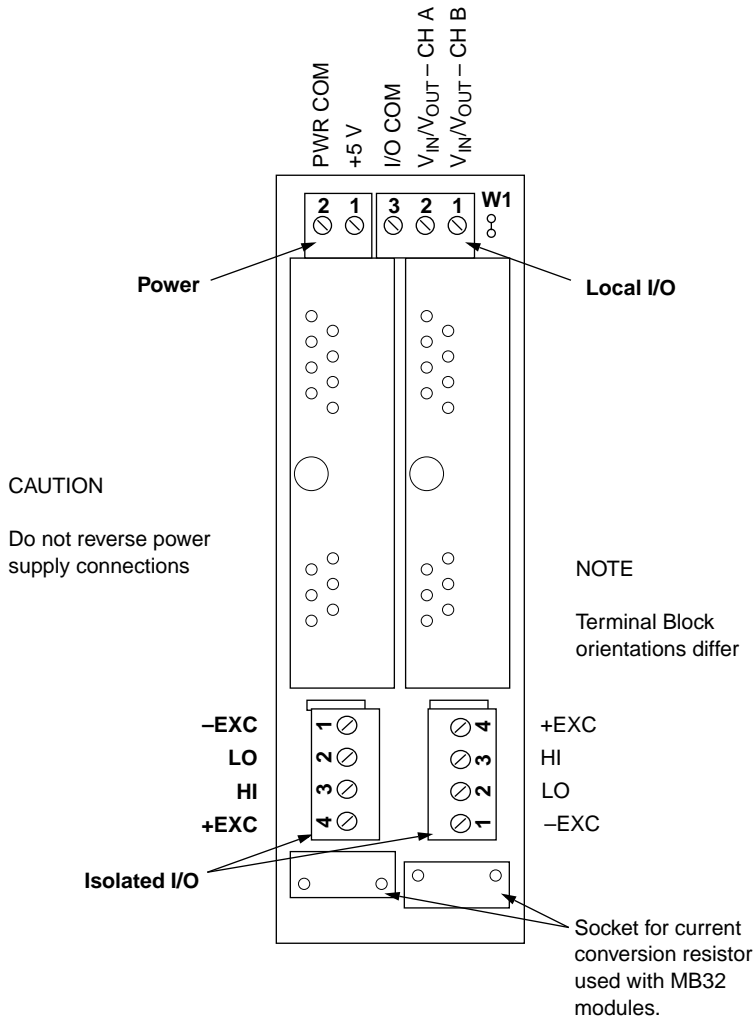

Figure 4-12. MB04 Wiring Diagram

Grounding

Jumper W1 connects +5 V power common to input/output common (backplane measurement ground). A connection between power common and input/output is important for the MB Series modules to function properly. However, if this connection is made elsewhere in your system (the best place is usually near the D/A or A/D converters), cut W1 to prevent a ground loop.

Power

All MB Series backplanes require external +5 V power. Chapter 2 describes the power connection.

Caution: The MB03 and MB04 are not protected against reversed power supply connections. A reversal may destroy the installed modules.

Field Terminations

All field terminations of signal wires are made at screw terminal blocks as discussed in Chapter 2. Refer also to Chapter 2 for diagrams of input and output screw terminal connections for specific modules.

Mounting

Individual backplanes are DIN-rail compatible using Phoenix Universal Mounting UM modules. You can mount two or more backplanes in wider UM assemblies.

Table 4-3 lists the Phoenix parts required for mounting a single MB03 or MB04 backplane. Table 4-4 lists the Phoenix parts required for mounting two or more backplanes. The snap foot elements will fit DIN EN 50022, DIN EN 50035, and DIN EN 50045 rails.

Table 4-3. MB03 and MB04 Mounting Parts

Model	Description (Phoenix Part)	Qty.
UM-BEFE	Base Element with Snap Foot	1
UM-SE	Side Element	2

Table 4-4. MB03 and MB04 Mounting Parts for Two or More Backplanes

Model	Description	Qty.
UM-BEFE	Base Element with Snap Foot	2
UM-SE	Side Element	2
UM-BE	Base Element	(#) - 2 ¹
UM-VS	Connection Pins	(4 x (#)) - 4 ¹

Notes

¹ # is the total number of MB03 and MB04 backplanes to be DIN-rail mounted

Specifications

Table 4-5 lists the specifications for the MB03 and MB04 backplanes. These are subject to change without notice.

Table 4-5. MB03 and MB04 Specifications

Specification	MB03	MB04
Channels	1	2
Physical Size (with modules)	4.25" x 1.365" (105 mm x 34.7 mm)	4.25" x 1.365" (105 mm x 34.7 mm)
Weight	.85 oz. (24.0 g)	1.06 oz. (30.2 g)
Power Supply	+5 VDC ±5%	+5 VDC ±5%

STA-1360 Evaluation Socket

The STA-1360 is a test or evaluation socket for MB Series modules. It provides screw terminals for all of the module's input, output, control, and power connections. In addition, it provides a cold junction temperature sensor for thermocouple applications, as well as a socket for installing the current sensing resistor used with the MB32 current input module. Figure 4-13 shows the wiring diagram of the STA-1360.

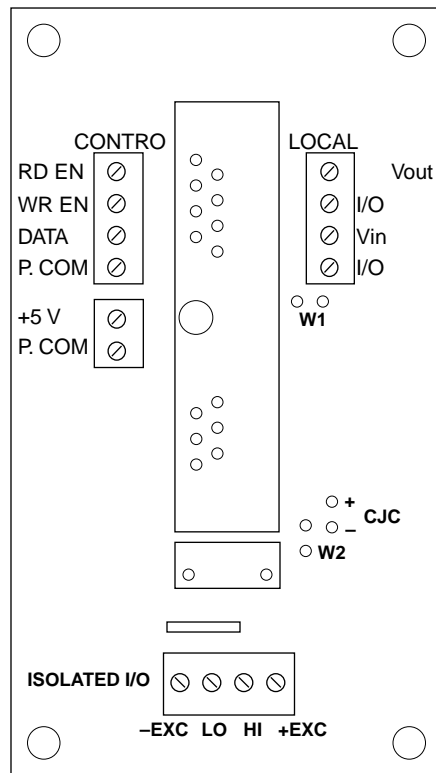

Figure 4-13. STA-1360 Backplane Diagram

Grounding

Jumper W1 provides the required current return path from I/O common on the non-isolated (system side) of the modules to the +5 V supply common. In general, this is not the best place to have such a connection. In most applications, there already is a suitable path resulting from a connection at another point so that W1 causes a ground loop. Virtually any contact between supply common and analog measurement common in the surrounding system is sufficient; the two grounds can be several volts apart and can have a resistance of up to 10 k Ω between them without affecting MB Series module operation. Cut W1 if such a contact exists.

Power

All MB Series backplanes require external +5 V power. Chapter 2 describes the power connection.

Caution: The STA-1360 is not protected against reversed power supply connections. A reversal may destroy the installed module.

Field Terminations

All field terminations of signal wires are made at screw terminal blocks as discussed in Chapter 2. Refer also to Chapter 2 for diagrams of input and output screw terminal connections for specific modules.

Cold Junction Compensation

Jumper W2 is factory installed and only affects the operation of thermocouple input modules. W2 connects the temperature sensor in its normal manner when a thermocouple input module is installed in the module socket. For applications involving connection of thermocouple wire to the HI and LO screw terminals, this results in normal correction in the module for the thermal effects of the connections.

If, however, you are using an MB37 or MB47 thermocouple module without thermocouple wire at the screw terminals – as, for example, in a test fixture using a millivolt source – disable the temperature sensor and substitute a suitable voltage to simulate operation at a chosen terminal temperature. Do this by opening jumper W2 and connecting a voltage source to the terminals labeled CJC. The required polarity of the applied voltage is by the terminal labeling. The source of the voltage must float with respect to anything connected to the HI and LO input terminals (or the \pm EXC screws, which are not normally used in thermocouple applications). Most benchtop calibration sources have the necessary isolation to work properly.

In these applications, a CJC voltage of 510.0 mV will simulate sensor operation at a terminal temperature of +25°C. Since there are no parasitic thermocouples at the screw terminals to correct, all output readings will appear to be 25°C higher than would be implied by the input voltage. With the 25°C shift taken into account, however, module operation is close to normal conditions for test or evaluation purposes. Alternatively, a CJC voltage of 572.5 mV can be applied, simulating operation at a terminal temperature of 0°C. Millivolt inputs can then be read directly from thermocouple tables without any temperature shift. At 572.5 mV, however, since the module's cold junction correction circuitry is operating far from its design center, its errors will be larger than would be the case in normal operation.

Mounting

The STA-1360 is DIN-rail compatible using Phoenix Universal Module UM elements. Table 4-6 lists the Phoenix parts required for mounting one STA-1360. The snap foot elements fit DIN EN 50022, DIN EN 50035, and DIN EN 50045 rails. Standoffs are included with each STA-1360 for bench top use or wall mounting.

Table 4-6. STA-1360 Mounting Parts

Model	Description	Qty.
UM-BEFE	Base Element with Snap Foot	2
UM-SE	Side Element	2
UM-VS	Connection Pins	4

STA-MB Backplane

The STA-MB backplane provides sockets for four MB Series modules. Two parallel 37-pin D-connectors provide interfaces for Keithley MetraByte analog I/O boards and accessories. The MB Series module inputs and outputs, as well as the I/O connector pins, are brought out to screw terminals. You can then wire the MB Series outputs to pins on the I/O connectors according to the requirements of your application.

For each module, the STA-MB provides a cold junction temperature sensor for thermocouple applications, as well as a socket for installing the current sensing resistor used with the MB32 current input module.

The STA-MB provides a set of DIP switches that lets you select either a single-ended or differential output configuration for each module. The single-ended setting (SE) grounds the low (-) output for the selected module so that only the high (+) output need be wired to the screw terminal input.

Figure 4-14 shows the layout and wiring of the STA-MB.

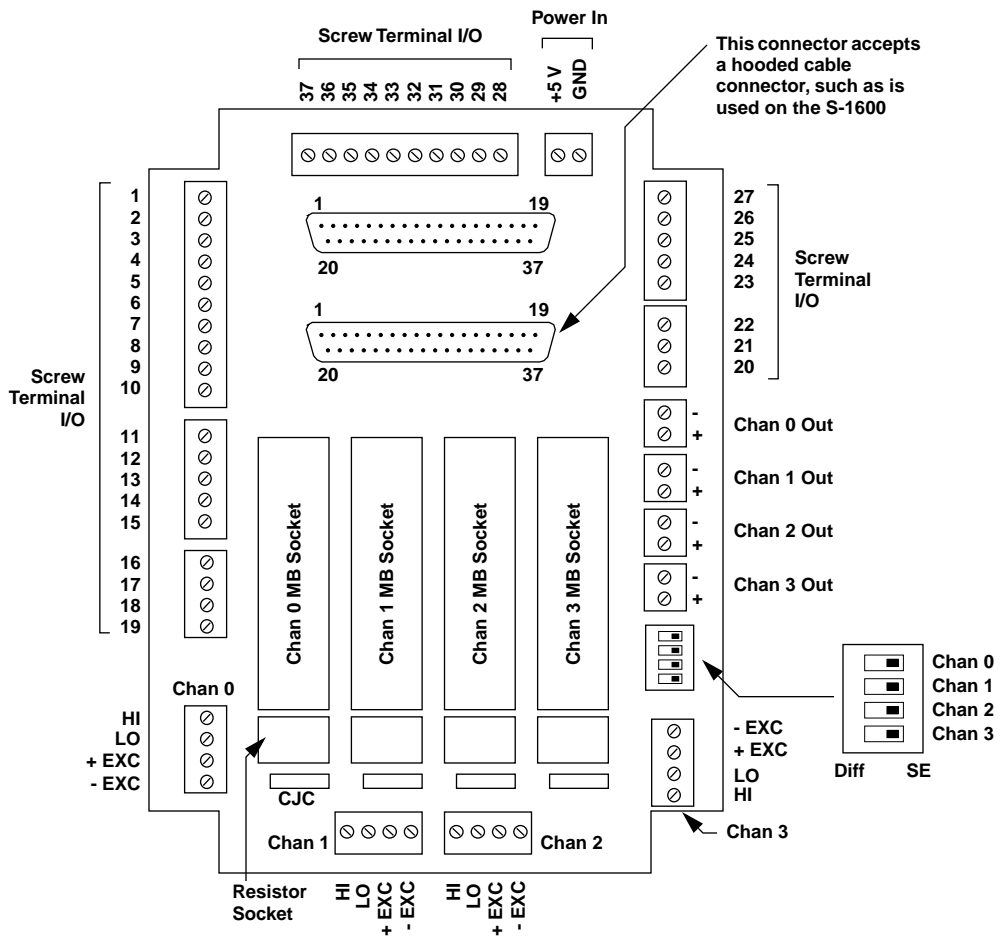

Figure 4-14. STA-MB Backplane Diagram

Power

All MB Series modules require +5 V power. You can use power either from the DAS board connection or an auxiliary power supply. In either case, you must wire the power to the power terminals (labeled +5 V and GND on the STA-MB). Refer to Figure 4-15 on page 4-24 for a diagram showing how to wire power from a DAS-1600 Series board.

Caution: The STA-MB is not protected against reversed power supply connections. A reversal may destroy the installed modules.

Mounting

The STA-MB mounts in a free-standing plastic enclosure that is open at the top.

Wiring

All field connections of signal wires are made at screw terminal blocks as discussed in Chapter 2. Refer also to Chapter 2 for diagrams of input and output screw terminal connections for specific modules.

In addition to field signal connections, you must wire the module outputs (Channel 0 Out - Channel 3 Out) to I/O connector pins as required for your application. You must have the pinout of your DAS board to do this. Figure 4-15 is an example showing the MB Series module on STA-MB Channel 0 Out wired to Channel 0 Hi In on a DAS-1600 Series board. This example also shows how to wire power from the DAS connection.

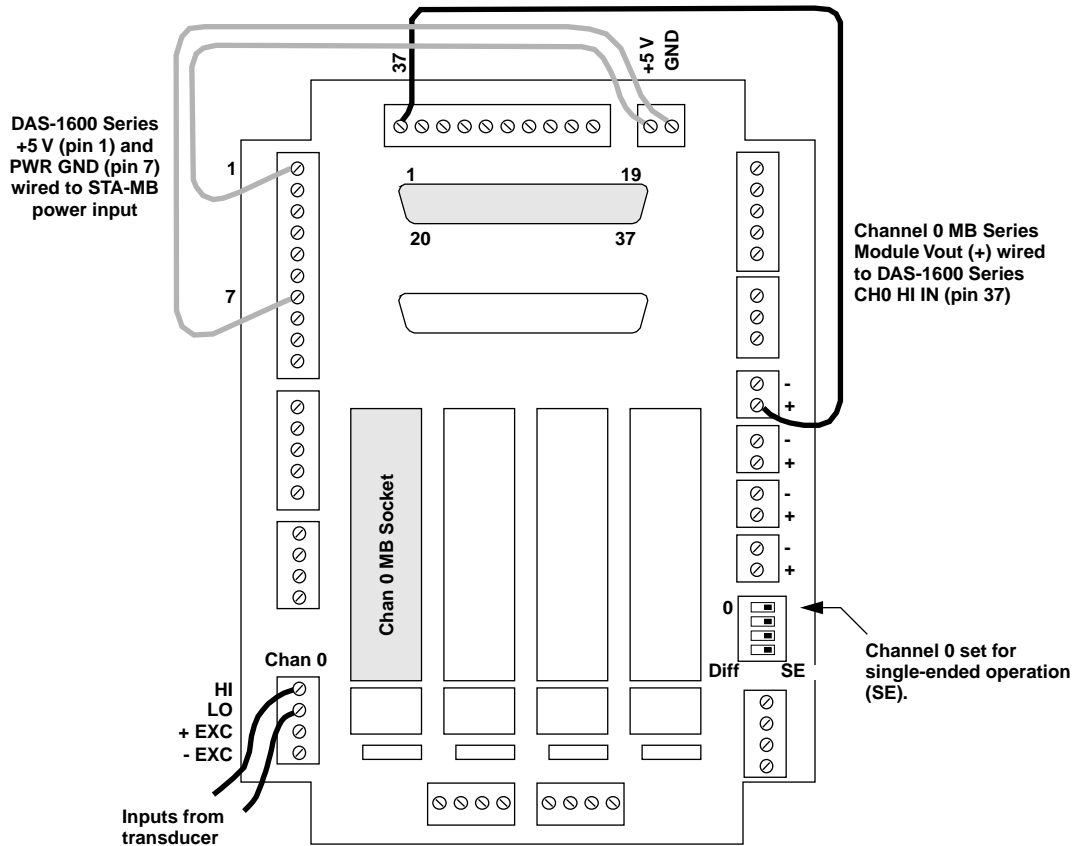

Figure 4-15. STA-MB/DAS-1600 Series Wiring Example

Index

A

accessory

- C-16MB1 2-20, 2-21, 2-22, 2-23
- C-1800 2-26, 2-37, 2-38, 2-39
- C-20MB1 2-23
- C-2600 2-26, 2-30
- C-8MB1 2-19
- CAB-3740 2-38, 2-39
- CACC-2000 2-30
- CDAS-2000 2-21
- CONN-1800HC 2-22
- STA-1800HC 2-22
- STA-1800U 2-30

accuracy 1-1

addressing (MB02) 4-9

anti-aliasing 1-6

applications, typical 1-9

B

backplanes

- MB01 1-8, 4-1
- MB02 1-8, 4-1
- MB03 1-8, 4-14
- MB04 1-8, 4-14
- MB05 1-8, 4-1
- STA-1360 1-8, 4-18
- STA-MB 1-8, 2-35, 4-21

Bessel filter 1-7, 3-48

Butterworth filter 1-7, 3-48

C

cable

- C-16MB1 2-20, 2-21, 2-22, 2-23
- C-1800 2-26, 2-37, 2-38, 2-39
- C-20MB1 2-23
- C-2600 2-26, 2-30
- C-8MB1 2-19
- CAB-3740 2-38, 2-39
- CACC-2000 2-30
- CDAS-2000 2-21
- shielding 4-5

cabling

- MB01 2-18
- MB02 2-24
- MB03, MB04, STA-1360 2-35
- MB05 2-18
- STA-MB 2-35, 2-37

channels, selecting on MB02 2-27, 2-31, 2-32

cold junction compensation 3-20, 3-43, 4-20

common mode rejection 1-2

connectors

- MB01 4-4
- MB02 4-6
- MB03 4-21
- MB05 4-4

current conversion resistor 2-17, 3-8

current input 3-7

current output module 3-29

D

DAS-1200 Series 2-20, 2-27, 2-39

DAS-1400 Series 2-20, 2-27, 2-39

DAS-16 2-20, 2-27

DAS-1600 Series 2-20, 2-27, 2-39

DAS-16F 2-20, 2-27

DAS-16G 2-20, 2-27

uCDAS-16G 2-20, 2-27

- DAS-20 2-23, 2-31
- DAS-4 2-19
- DAS-8 2-19, 2-38
- DAS-8/AO 2-19
- DAS-800 Series 2-19, 2-37, 2-38
- DAS-8PGA 2-19
- uCDAS-8PGA 2-19
- DASCard-1000 Series 2-39
- differential inputs 2-18
- differential outputs, STA-MB 2-37
- dimensions
 - MB01, MB02, and MB05 4-10
 - module 1-3
- DIN-rail mounting 4-16
- drift 1-2

E

- EXP-16 2-38
- EXP-1600 2-39
- EXP-800 2-38

F

- field I/O 2-12
- filters
 - Bessel 1-6, 3-48
 - Butterworth 1-6, 3-48
 - low-pass 1-6
- fire retardance 1-2
- frequency input 3-39
- full-bridge strain gauge 3-25

G

- ground loop 4-7, 4-8, 4-19
- grounding 4-7
 - MB01, MB02, and MB05 4-7
 - MB03 and MB04 4-16
 - STA-1360 4-19

H

- half-bridge strain gauge 3-25

I

- IEEE-STD 472 1-2
- inputs
 - current 3-7
 - frequency 3-39
 - linearized thermocouple 3-43
 - millivoltage 3-2
 - millivoltage (wide bandwidth) 3-34
 - potentiometer 3-16
 - RTD 3-11
 - single-ended vs. differential 2-18
 - strain gauge 3-25
 - thermocouple 3-20
 - voltage 3-2
 - voltage (wide bandwidth) 3-34
- installing modules 2-11
- interchannel bridge jumpers 4-9
- isolation 4-9
 - transformer 1-2

J

jumpers

- address selection 4-9
- interchannel bridge 4-9
- MB01, MB02, and MB05 4-7
- MB03 and MB04 4-16
- STA-1360 4-19, 4-20

L

- labeling 1-2
- linearized thermocouple input 3-43
- low-pass filters 1-6

M

- MB01 backplane 1-8, 4-1
- MB02 backplane 1-8, 2-29, 4-1
- MB03 backplane 1-8, 4-14
- MB04 backplane 1-8, 4-14
- MB05 backplane 1-8, 4-1
- MBAF Series filter modules 1-6, 3-48
- millivoltage (wide bandwidth) input 3-34
- millivoltage input 3-2
- module descriptions
 - MB30 millivoltage input 3-2
 - MB31 voltage input 3-2
 - MB32 current input 3-7
 - MB34 RTD input 3-11
 - MB36 potentiometer input 3-16
 - MB37 thermocouple input 3-20
 - MB38 strain gauge input 3-25
 - MB39 current output 3-29
 - MB40 millivoltage (wide bandwidth) input 3-34
 - MB41 voltage (wide bandwidth) input 3-34
 - MB45 frequency 3-39

- MB47 linearized thermocouple 3-43
- MBAF series 3-48

mounting

- DIN-rail 4-16
- MB01, MB02, and MB05 2-2, 4-10
- MB03 and MB04 2-3, 4-16
- STA-1360 2-3, 4-21
- STA-MB 2-3

N

- normal mode rejection 1-2

O

- output current 3-29

P

- performance 1-1
- Phoenix parts 4-16
- pinout
 - MB01 connectors 4-4
 - MB02 connector 4-6
 - MB05 connectors 4-4
 - module 1-3
- polarity reversal
 - MB01, MB02, and MB05 4-8
 - MB03 and MB04 4-16
 - STA-MB 4-23
- potentiometer input 3-16
- power requirements 2-4
- power supplies, PWR-51A and PWR-55A 2-4
- power, connecting
 - MB01, MB02, and MB05 2-5
 - MB03, MB04, STA-1360 2-6
 - STA-MB 2-7

process current input 3-7
protection, against transient voltages 1-2

Q

quarter-bridge strain gauge 3-26

R

rack enclosure 4-12
resistor, current conversion 2-17, 3-8
RFI/EMI immunity 1-2
RMT-MBBP rack enclosure 4-12
RTD input 3-11

S

shielding 4-5
signals, connecting 2-12
single-ended inputs 2-18
single-ended outputs, STA-MB 2-37
STA-1360 backplane 1-8, 4-18
STA-1800U accessory 2-30
STA-MB backplane 1-8, 4-21
 cabling 2-37
 wiring 4-23
STA-SCM16 interface board 2-27
STA-SCM8 interface board 2-25
strain gauge input 3-25

T

thermocouple input 3-20
three-quarter-bridge strain gauge 3-26
track-and-hold 3-29
transformer isolation 1-2
transient protection 4-7

V

voltage (wide bandwidth) input 3-34
voltage input 3-2

W

wiring
 physical 2-12
 specific modules 2-13
 STA-MB 4-23

Specifications are subject to change without notice.

All Keithley trademarks and trade names are the property of Keithley Instruments, Inc. All other trademarks and trade names are the property of their respective companies.



Keithley Instruments, Inc.

28775 Aurora Road • Cleveland, Ohio 44139 • 440-248-0400 • Fax: 440-248-6168
1-888-KEITHLEY (534-8453) • www.keithley.com

Sales Offices: BELGIUM:

Bergensesteenweg 709 • B-1600 Sint-Pieters-Leeuw • 02-363 00 40 • Fax: 02/363 00 64

CHINA:

Yuan Chen Xin Building, Room 705 • 12 Yumin Road, Dewai, Madian • Beijing 100029 • 8610-6202-2886 • Fax: 8610-6202-2892

FINLAND:

Tietäjäsentie 2 • 02130 Espoo • Phone: 09-54 75 08 10 • Fax: 09-25 10 51 00

FRANCE:

3, allée des Garays • 91127 Palaiseau Cédex • 01-64 53 20 20 • Fax: 01-60 11 77 26

GERMANY:

Landsberger Strasse 65 • 82110 Germering • 089/84 93 07-40 • Fax: 089/84 93 07-34

GREAT BRITAIN:

Unit 2 Commerce Park, Brunel Road • Theale • Berkshire RG7 4AB • 0118 929 7500 • Fax: 0118 929 7519

INDIA:

Flat 2B, Willocrissa • 14, Rest House Crescent • Bangalore 560 001 • 91-80-509-1320/21 • Fax: 91-80-509-1322

ITALY:

Viale San Gimignano, 38 • 20146 Milano • 02-48 39 16 01 • Fax: 02-48 30 22 74

JAPAN:

New Pier Takeshiba North Tower 13F • 11-1, Kaigan 1-chome • Minato-ku, Tokyo 105-0022 • 81-3-5733-7555 • Fax: 81-3-5733-7556

KOREA:

2FL., URI Building • 2-14 Yangjae-Dong • Seocho-Gu, Seoul 137-888 • 82-2-574-7778 • Fax: 82-2-574-7838

NETHERLANDS:

Postbus 559 • 4200 AN Gorinchem • 0183-635333 • Fax: 0183-630821

SWEDEN:

c/o Regus Business Centre • Frosundaviks Allé 15, 4tr • 169 70 Solna • 08-509 04 679 • Fax: 08-655 26 10

SWITZERLAND:

Kriesbachstrasse 4 • 8600 Dübendorf • 01-821 94 44 • Fax: 01-820 30 81

TAIWAN:

1FL., 85 Po Ai Street • Hsinchu, Taiwan, R.O.C. • 886-3-572-9077 • Fax: 886-3-572-9031